

**DOCUMENTATION**

**ASC GUN**

**Manual : 582.107.110-UK - 1905**

*Date: 03/05/19*

*Supersede : 22/03/19*

*Modif.:*

**TRANSLATION FROM THE ORIGINAL MANUAL**

***IMPORTANT : Before assembly and start-up, please read and clearly understand all the documents relating to this equipment (professional use only).***

THE PICTURES AND DRAWINGS ARE NON CONTRACTUAL. WE RESERVE THE RIGHT TO MAKE CHANGES WITHOUT PRIOR NOTICE..

**SAMES KREMLIN SAS**  
13, chemin de Malacher  
38 240 - MEYLAN - France  
 : 33 (0)4 76 41 60 60

**[www.sames-kremlin.com](http://www.sames-kremlin.com)**



<p align="center"><b>FR</b></p> <p><b>Pour une utilisation sûre, il est de votre responsabilité de :</b></p> <ul style="list-style-type: none"> <li>• Lire attentivement tous les documents contenus dans le CD joint avant la mise en service de l'équipement,</li> <li>• D'installer, d'utiliser, d'entretenir et de réparer l'équipement conformément aux préconisations de SAMES KREMLIN ainsi qu'aux réglementations nationales et/ou locales,</li> <li>• Vous assurez que les utilisateurs de cet équipement ont été formés, ont parfaitement compris les règles de sécurité et qu'ils les appliquent.</li> </ul>	<p align="center"><b>UK</b></p> <p><b>To ensure safe use of the machinery, it is your responsibility to:</b></p> <ul style="list-style-type: none"> <li>• Carefully read all documents contained on the enclosed CD before putting the machinery into service,</li> <li>• Install, use, maintain and repair the machinery in accordance with SAMES KREMLIN's recommendations and national and/or local regulations,</li> <li>• Make sure that the users of the machinery have received proper training and that they have perfectly understood the safety rules and apply them.</li> </ul>	<p align="center"><b>DE</b></p> <p><b>Eine sichere Nutzung setzt voraus, dass Sie :</b></p> <ul style="list-style-type: none"> <li>• alle in der CD enthaltenen Dokumente vor der Inbetriebnahme der Anlage aufmerksam lesen,</li> <li>• die Anlage im Einklang mit den Empfehlungen von SAMES KREMLIN sowie mit den nationalen und/oder lokalen Bestimmungen installieren, verwenden, warten und reparieren,</li> <li>• sich vergewissern, dass die Nutzer dieser Anlage angemessen geschult wurden, die Sicherheitsbestimmungen verstanden haben und sie anwenden.</li> </ul>
<p align="center"><b>ES</b></p> <p><b>Para una utilización segura, será de su responsabilidad:</b></p> <ul style="list-style-type: none"> <li>• leer atentamente todos los documentos que se incluyen en el CD adjunto antes de la puesta en servicio del equipo,</li> <li>• instalar, utilizar, efectuar el mantenimiento y reparar el equipo con arreglo a las recomendaciones de SAMES KREMLIN y a la normativa nacional y/o local,</li> <li>• cerciorarse de que los usuarios de este equipo han recibido la formación necesaria, han entendido perfectamente las normas de seguridad y las aplican.</li> </ul>	<p align="center"><b>IT</b></p> <p><b>Per un uso sicuro, vi invitiamo a:</b></p> <ul style="list-style-type: none"> <li>• leggere attentamente tutta la documentazione contenuta nel CD allegato prima della messa in funzione dell'apparecchio,</li> <li>• installare, utilizzare, mantenere e riparare l'apparecchio rispettando le raccomandazioni di SAMES KREMLIN, nonché le normative nazionali e/o locali,</li> <li>• accertarvi che gli utilizzatori dell'apparecchio abbiano ricevuto adeguata formazione, abbiano perfettamente compreso le regole di sicurezza e le applichino.</li> </ul>	<p align="center"><b>PT</b></p> <p><b>Para uma utilização segura, é da sua responsabilidade:</b></p> <ul style="list-style-type: none"> <li>• Ler atentamente todos os documentos incluídos no CD em anexo antes de pôr o equipamento em funcionamento,</li> <li>• Proceder à instalação, utilização, manutenção e reparação do equipamento de acordo com as preconizações de SAMES KREMLIN, bem como com outros regulamentos nacionais e/ou locais aplicáveis,</li> <li>• Assegurar-se que os utilizadores do equipamento foram devidamente capacitados, compreenderam perfeitamente e aplicam as devidas regras de segurança.</li> </ul>
<p align="center"><b>NL</b></p> <p><b>Voor een veilig gebruik dient u:</b></p> <ul style="list-style-type: none"> <li>• alle document op de bijgevoegde cd aandachtig te lezen alvorens het apparaat in werking te stellen,</li> <li>• het apparaat te installeren, gebruiken, onderhouden en repareren volgens de door SAMES KREMLIN gegeven aanbevelingen en overeenkomstig de nationale en/of plaatselijke reglementering,</li> <li>• zeker te stellen dat de gebruikers van dit apparaat zijn opgeleid, de veiligheidsregels perfect hebben begrepen en dat zij die ook toepassen.</li> </ul>	<p align="center"><b>SE</b></p> <p><b>För en säker användning av utrustningen ansvarar ni för följande:</b></p> <ul style="list-style-type: none"> <li>• Läs noga samtliga dokument som finns på den medföljande cd-skivan innan utrustningen tas i drift.</li> <li>• Installera, använd, underhåll och reparera utrustningen enligt anvisningarna från SAMES KREMLIN och enligt nationella och/eller lokala bestämmelser.</li> <li>• Försäkra er om att användare av denna utrustning erhållit utbildning, till fullo förstått säkerhetsföreskrifterna och tillämpar dem.</li> </ul>	<p align="center"><b>FI</b></p> <p><b>Käytön turvallisuuden varmistamiseksi velvollisuutesi on:</b></p> <ul style="list-style-type: none"> <li>• Lukea huolella kaikki CD:llä olevat asiakirjat ennen laitteiston käyttöönottoa,</li> <li>• Noudattaa laitteiston asennuksessa, käytössä, kunnossapidossa ja huollossa SAMES KREMLIN in suosituksia sekä kansallisia ja/tai paikallisia määräyksiä,</li> <li>• Varmistaa, että laitteiston käyttäjät ovat koulutettuja ja ymmärtävät täysin turvallisuusmääräykset ja miten niitä sovelletaan.</li> </ul>
<p align="center"><b>PL</b></p> <p><b>Dla zapewnienia bezpiecznego użytkowania na użytkownika spoczywa obowiązek:</b></p> <ul style="list-style-type: none"> <li>• Uważnego zapoznania się ze wszystkimi dokumentami znajdującymi się na załączonej płycie CD przed pierwszym uruchomieniem urządzenia,</li> <li>• Instalowania, użytkowania, konserwacji i naprawy urządzenia zgodnie z zaleceniami firmy SAMES KREMLIN oraz z przepisami miejscowymi,</li> <li>• Upewnienia, że wszyscy przeszkoleni użytkownicy urządzenia zrozumieli zasady bezpieczeństwa i stosują się do nich.</li> </ul>	<p align="center"><b>CS</b></p> <p><b>Pro bezpečné používání jste povinni:</b></p> <ul style="list-style-type: none"> <li>• Před uvedením zařízení do provozu si pozorně přečíst veškeré dokumenty obsažené na příloženém CD,</li> <li>• Nainstalovat, používat, udržovat a opravovat zařízení v souladu s pokyny firmy SAMES KREMLIN a s národními a/nebo místními legislativními předpisy,</li> <li>• Ujistit se, že uživatelé tohoto zařízení byli vyškoleni, že dokonale pochopili bezpečnostní pravidla a že je dodržují.</li> </ul>	<p align="center"><b>SL</b></p> <p><b>Za varno uporabo ste dolžni:</b></p> <ul style="list-style-type: none"> <li>• natančno prebrati vse dokumente na CD pred zagonom stroja,</li> <li>• instalirati, uporabljati, vzdrževati in popravljati opremo po določilih SAMES KREMLIN in v skladu z veljavnimi nacionalnimi in/ali lokalnimi predpisi,</li> <li>• poskrbeti, da so uporabniki te opreme ustrezno usposobljeni, poznajo varnostne predpise in da jih upoštevajo.</li> </ul>
<p align="center"><b>SK</b></p> <p><b>V záujme bezpečného je vašou povinnosťou:</b></p> <ul style="list-style-type: none"> <li>• pozorne si prečítať všetky dokumenty obsiahnuté na priloženom CD predtým, ako zariadenie uvediete do prevádzky,</li> <li>• nainštalovať, používať, udržiavať a opravovať zariadenie v súlade s odporúčaniami spoločnosti SAMES KREMLIN a národnými a/alebo miestnymi predpismi,</li> <li>• uistiť sa, že používatelia tohto zariadenia boli zaškolení, riadne porozumeli pravidlám bezpečnosti a používajú ich.</li> </ul>	<p align="center"><b>HU</b></p> <p><b>A biztonságos használat érdekében az Ön felelőssége, hogy:</b></p> <ul style="list-style-type: none"> <li>• a berendezés üzembe helyezése előtt figyelmesen elolvassa a mellékelt CD által tartalmazott összes dokumentumot,</li> <li>• a berendezést a SAMES KREMLIN ajánlásainak valamint a nemzeti és/vagy helyi szabályozásoknak megfelelően helyezze üzembe, használja, tartsa karban és javítsa,</li> <li>• megbizonyosodjon róla, hogy a berendezés felhasználói képzettek, tökéletesen megértették és alkalmazzák a biztonsági előírásokat.</li> </ul>	<p align="center"><b>RO</b></p> <p><b>Pentru o utilizare sigură, este responsabilitatea dvs. să:</b></p> <ul style="list-style-type: none"> <li>• Citiți cu atenție toate documentele de pe CD-ul anexat, înainte de punerea în funcțiune a echipamentului,</li> <li>• Instalați, utilizați, întrețineți și reparați echipamentul conform instrucțiunilor SAMES KREMLIN precum și reglementărilor naționale și/sau locale,</li> <li>• Vă asigurați că utilizatorii acestei echipament au fost instruiți, au înțeles perfect regulile de securitate și le aplică integral.</li> </ul>

Declaration(s) de conformité au verso de ce document / Declaration(s) of conformity at the back of this document / Konformitätserklärung(en) auf der Rückseite dieser Unterlage / Declaración (es) de conformidad en el reverso de este documento / Dichiarazione/i di conformità sul retro del presente documento / Declaração(ões) de conformidade no verso do documento / Conformiteitsverklaring(en) op de keerzijde van dit document / Försäkran om överensstämmelse på omstående sida av detta dokument / Vaatimustenmukaisuusvakuutukset tämän asiakirjan kääntöpuolella / Deklaracja(e) zgodności na odwrocie dokumentu / Prohlášení o shodě se nachází/nacházejí na zadní straně tohoto dokumentu / Deklaracija(e) o skladnosti na hrbtni strani tega dokumenta / Vyhlášení/-a o zhode sa nachádzajú na zadnej strane dokumentu / A dokumentum hátlapján szereplő megfelelési nyilatkoz(ok) / Declarații de conformitate pe versoul acestui document



**DECLARATION UE DE CONFORMITE**  
**UE DECLARATION OF CONFORMITY**  
**EU- KONFORMITÄTSEKTLÄRUNG**  
**DECLARACIÓN UE DE CONFORMIDAD**  
**DICHIARAZIONE DI CONFORMITÀ UE**  
**DECLARAÇÃO UE DE CONFORMIDADE**  
**EU-CONFORMITEITSVERKLARING**  
**EU-FÖRSÄKRAN OM ÖVERENSSTÄMMELSE**  
**EU- VAATIMUKSEN MUKAISUUSVAKUUTUS**  
**DEKLARACJA ZGODNOŚCI UE**  
**EU PROHLÁŠENÍ O SHODĚ**  
**IZJAVA EU O SKLADNOSTI**  
**VYHLÁSENIE O ZHODE**  
**EU-MEGFELELŐSÉGI NYILATKOZAT**  
**DECLARAȚIA DE CONFORMITATE UE**

Le fabricant / The manufacturer / Der Hersteller / El fabricante / Il produttore / O fabricante / De fabrikant / Tillverkare / Valmistaja / Producent / Výrobce / Proizvajalec / Výrobca / Gyártó / Fabricantul:	<b>SAMES KREMLIN SAS</b> 13, chemin de Malacher 38 240 - MEYLAN - FRANCE Tél. : 33 (0)4 76 41 60 60
---	--

Déclare que le matériel désigné ci-après / Herewith declares that the equipment / erklärt hiermit, dass die / Declara que el material designado a continuación / Dichiaro che il materiale sottoindicato / Declara que o material a seguir designado / verklaart dat de hieronder aangeduide apparatuur / Kungör att den utrustning som anges här nedan / ilmoittaa, että alla mainitut laitteistot / Oświadcza, że wymienione poniżej urządzenia / Prohlašuje, že níže uvedené vybavení / Izjavlja, da je opisana oprema spodaj / Vyhlasuje, že zariadenie uvedené nižšie / Kijelenti, hogy a megjelölt anyag a továbbiakban / Declară că echipamentul precizat mai jos:

**PISTOLET AUTOMATIQUE DE PULVERISATION AIRLESS® / AIRLESS AUTOMATIC SPRAYING GUN**  
**/ AIRLESS SPRITZPISTOLEN / PISTOLA AUTOMÁTICA DE PULVERIZACIÓN AIRLESS**

ASB 240
ASC 240
ASC 400

Est conforme à la législation d'harmonisation de l'Union applicable suivante / Is in conformity with the relevant Union harmonisation legislation / Erfüllt die einschlägigen Harmonisierungsrechtsvorschriften der Union / es conforme con la legislación de armonización pertinente de la Unión / è conforme alla pertinente normativa di armonizzazione dell'Unione / in overeenstemming met de desbetreffende harmonisatiewetgeving van de Unie / med den relevanta harmoniserade unionslagstiftningen / on asiaa koskevan unionin yhdenmukaistamislainsäädännön vaatimusten mukainen / jest zgodny z odnośnymi wymaganiami unijnego prawodawstwa harmonizacyjnego / Shoduje se s následující příslušnou evropskou harmonizační legislativou / V skladu s harmonizirano zakonodajo Unije / Je v súlade s uplatniteľnými harmonizačnými právnymi predpismi EÚ / Megfelelő a következő alkalmazandó uniós harmonizációs szabályozásnak / Este conform cu legislația aplicabilă de armonizare de mai jos

Directive ATEX / ATEX Directive / ATEX Richtlinie / Directiva ATEX / Direttiva ATEX / Diretiva ATEX / ATEX-Richtlijn / ATEX-direktivet / ATEX-direktivi / Dyrektywa ATEX / Směrnice ATEX / Direktiva ATEX / Smernica ATEX / ATEX-irányelv	 II 2G Ex h IIB T6 Gb		
NF-EN ISO 80079-36			
Procédure d'évaluation de la conformité : Module A Documentation technique (Annexe VIII) archivée par : / Conformity assessment procedure: Module A Technical documentation (ANNEX VIII) recorded by: / Verfahren zur Konformitätsbewertung: Modul A Technische Unterlagen (ANLAGE VIII) archiviert durch: / Procedimiento de evaluación de la conformidad: Módulo A Documentación técnica (ANEXO VIII) archivada por: / Procedura di valutazione della conformità: Modulo A Documentazione tecnica (ALLEGATO VIII) archiviata a cura di: / Procedimento de avaliação da conformidade: Módulo A Documentação técnica (ANEXO VIII) arquivada por: / Conformiteitsbeoordelingsprocedure: Module A Technische documentatie (BIJLAGE VIII) gearhiveerd door: / Förfarande för bedömning av överensstämmelse: Modul A Teknisk dokumentation (BILAGA VIII) arkiverad av: / Vaatimusten mukaisuusarviointimenetelmä: moduuli A Tekninen dokumentaatio (LIITE VIII) arkistoitu: / Procedura oceny zgodności: Modul A Dokumentacja technicznej (ZAŁĄCZNIK VIII) zarchiwizowane przez: / Postup posuzování shody: Modul A Technická dokumentace (PŘÍLOHA VIII) archivována: / Postopek preverjanja skladnosti: Modul A Tehnična dokumentacija (PRILOGA VIII), arhiviral: / Postup posudzovania zhody: Modul A Technická dokumentácia (PRÍLOHA VIII) archivovaná prostredníctvom: / Megfelelősgértékelési eljárás: A. modul Műszaki dokumentáció (VIII. MELLÉKLET) archiválta: / Procedura de evaluare a conformității: Modulul A Documentația tehnică (ANEXA VIII) este arhivată de:		<b>2014/34/UE</b>	
N°INERIS 034299 / 19	INERIS 0080 - 60550 Verneuil-en-Halatte - France		

La présente déclaration de conformité est établie sous la seule responsabilité du fabricant / This declaration of conformity is issued under the sole responsibility of the manufacturer / Die alleinige Verantwortung für die Ausstellung dieser Konformitätserklärung trägt der Hersteller / La presente declaración de conformidad se expide bajo la exclusiva responsabilidad del fabricante / La presente dichiarazione di conformità è rilasciata sotto la responsabilità esclusiva del fabbricante / A presente declaração de conformidade é emitida sob a exclusiva responsabilidade do fabricante / Deze conformiteitsverklaring wordt verstrekt onder volledige verantwoordelijkheid van de fabrikant / Denna försäkran om överensstämmelse utfärdas på tillverkarens eget ansvar / Tämä vaatimustenmukaisuusvakuutus on annettu valmistajan yksinomaisella vastuulla / Niniejsza deklaracja zgodności wydana zostaje na wyłączną odpowiedzialność producenta / Toto prohlášení o skodě se vydává na výhradní odpovědnost výrobce / Za izdajo te izjave o skladnosti je odgovoren izključno proizvajalec / Toto vyhlásenie o zhode sa vydáva / na vlastnú zodpovednosť výrobcu / Ezt a megfelelőségi nyilatkozatot a gyártó kizárólagos felelősége mellett adják ti / Prezenta declarație de conformitate este emisă pe răspunderea exclusivă a producătorului.



Hervé WALTER

Directeur Innovation & Développement / Innovation & Development Director / Direktor für Innovation & Entwicklung / Director de Innovación y Desarrollo / Direttore Innovazione e sviluppo / Diretor de Inovação / Manager Innovatie en Ontwikkeling / Direktör för Forskning och Utveckling / Innovaatio- ja kehitysjohtaja / Dyrektor ds. Innowacji i Rozwoju / Ředitel pro inovace a vývoj / Direktor za inovacije in razvoj / Riaditeľ pre inováciu a rozvoj / Innovációs és fejlesztési igazgató / Director Inovație și Dezvoltare

Fait à Meylan, le / Established in Meylan, on / Geschehen zu Meylan, am / En Meylan, a / Redatto a Meylan, / Vastgesteld te Meylan, / Utformat i Meylan, den / Meylan, Ranska, / Sporządzono w Meylan, dnia / Meylan, dnia / V Meylanu, / V Meylan dňa / Kelt Meylanban, / Întocmită la Meylan, pe data de 01/05/2019 - 05/01/2019



# INSTALLATION AND SAFETY INSTRUCTIONS

## TRANSLATION FROM THE ORIGINAL MANUAL

**IMPORTANT** : Before assembly and start-up, please read and clearly understand all the documents relating to this equipment (professional use only).

THE PICTURES AND DRAWINGS ARE NON CONTRACTUAL. WE RESERVE THE RIGHT TO MAKE CHANGES WITHOUT PRIOR NOTICE.

**SAMES KREMLIN SAS**  
13, chemin de Malacher  
38 240 - MEYLAN - France  
☎ : 33 (0)4 76 41 60 60  
  
**[www.sames-kremlin.com](http://www.sames-kremlin.com)**

# 1. SAFETY INSTRUCTIONS

## GENERAL SAFETY INSTRUCTIONS



**CAUTION :** The equipment can be dangerous if you do not follow our instructions concerning installation and servicing described in this manual and in accordance with applicable European standards and local national safety regulations.

Please carefully read all the instruction literature before operating your equipment.

### **Only trained operators can use the equipment.**

The foreman must ensure that the operator has understood the safety instructions for this equipment as well as the instructions in the manuals for the different parts and accessories.

Read carefully all instruction manuals, label markings before operating the equipment.



















Incorrect use may result in injury. This equipment is for professional use only. It must be used only for what it has been designed for. Never modify the equipment. The parts and accessories supplied must be regularly inspected. Defective or worn parts must be replaced.

**Guards (motor cover, coupling shields, connectors,...) have been designed for a safe use of the equipment.  
The manufacturer will not be held responsible for bodily injury or failure and / or property damage due to destruction, the overshadowing or the partial or total removal of the guards.**

### **Never exceed the equipment components' maximum working pressure.**

Comply with regulations concerning safety, fire risks, electrical regulations in force in the country of final destination of the material. Use only products or solvent compatible with the parts in contact with the material (refer to data sheet of the material manufacturer).

## PICTOGRAMS

					
NIP HAZARD	WARNING MOVING ELEVATOR	WARNING MOVING PARTS	WARNING MOVING SHOVEL	DO NOT EXCEED THIS PRESSURE	HIGH PRESSURE HAZARD
					
RELIEF OR DRAIN VALVE	WARNING HOSE UNDER PRESSURE	WEAR GLASSES OBLIGATORY	WEAR OF GLOVES IS OBLIGATORY	PRODUCT VAPOR HAZARDS	WARNING HOT PARTS OR AREAS
					
ELECTRICAL HAZARD	WARNING FIRE HAZARDS	EXPLOSION HAZARDS	GROUNDING	WARNING (USER)	WARNING SERIOUS INJURIES

## PRESSURE HAZARDS



Current legislation requires that an **air relief** valve be fitted in the air supply circuit to the air motor to prevent over pressurisation. This safety feature ensures that it is not possible to supply the air motor with excessive air pressure that may cause injury.

Please ensure that a **material drain valve** is fitted in the fluid circuit to drain and depressurise the circuit. Once depressurised and drained, work /servicing may then commence on the equipment. Please remember to close these valves when restarting the system.

## HIGH PRESSURE INJECTION HAZARDS



When working with high pressure equipment, special care is required. Fluid leaks can occur. There is a risk of material being injected to any exposed parts of body, this could cause severe injury :



- medical care must be sought immediately if paint is injected under the skin or in other parts of the body (eyes, fingers).
- never point the spray gun at any one. Never try to stop the spray with your hands or fingers nor with rags or similars.
- **follow the shut down procedure and always depressurize air and fluid circuits** before carrying out any servicing on the gun (cleaning, checking, maintenance of the material or cleaning of the gun nozzles).
- for the guns equipped with a safety device, always lock the trigger when not in use.

## FIRE - EXPLOSION - SPARKS - STATIC ELECTRICITY HAZARDS

A poor earth connection, inadequate ventilation, sparks or static electricity can cause an explosion or fire. to avoid these risks when using or servicing SAMES KREMLIN equipment, the following safety procedures must be followed :



- ensure a good earth connection and ground the parts to be handled i.e. solvents, materials, components and equipment,
- ensure adequate ventilation,
- keep working area clean and free from waste solvents, chemicals, or solid waste i.e. rags, paper and empty chemicals drums,
- never use electrical switches / power if in an atmosphere of volatile solvent vapour,
- stop working immediately in case of electrical arcs,
- never store chemicals and solvents in the working area.
- use paint whose flash point is the highest possible to prevent from any formation of gas and inflammable vapours (refer to materials' safety instructions),
- install a cover on the drums to reduce the diffusion of gas and vapours in the spraybooth.

## TOXIC PRODUCT HAZARDS



Toxic products or vapours can cause severe injury not only through contact with the body, but also if the products are ingested or inhaled. It is imperative :

- to know the material products and their risks,
- notified or hazardous materials must be stored in accordance with the regulations,
- the material must be stored in an appropriate container, never place materials in a container where there is a risk of spillage or leakage,
- a procedure must be applied for the safe disposal of waste material. It must comply with all prevailing regulations and legislations of the country where the equipment is to be used,
- protective clothing should always be worn in compliance with the material manufacturers' recommendations,
- depending on the application and chemical safety instructions, safety glasses, hearing protective earplug, gloves, foot wear, protective masks and possible breathing equipment should be worn to comply with the regulations (Refer to chapter "Safety equipment of SAMES KREMLIN selection guide).



### CAUTION!

It is forbidden to use material containing high concentrations of halogenated hydrocarbon solvents with **aluminium** or **zinc fillers**. Non-compliance with the instructions may cause explosion risk causing serious or fatal injury.



### EQUIPMENT REQUIREMENTS

**Guards (motor cover, coupling shields, connectors,...) have been designed for a safe use of the equipment.**

**The manufacturer will not be held responsible for bodily injury or failure and / or property damage due to destruction, the overshadowing or the partial or total removal of the guards.**

### PUMP



Before carrying out any work, it is imperative to read and clearly understand the disassembly and reassembly instructions before servicing. The operator must understand the equipment and the safety instructions. These instructions are available in the equipment manuals.



The air motor is designed to be mounted with a pump. Never modify any components or couplings. When operating, please keep hands away from moving parts. Before starting up the equipment, please read the PRESSURE RELIEF instructions. Please ensure that any relief or drain valves fitted are in good working order.

### HOSES

- Keep hoses out of circulation areas, moving parts or hot surfaces,
- Never expose product hoses to temperature higher than + 60°C / 140° F or lower than 0°C / 32° F,
- Never pull or use the hoses to move the equipment,
- Tighten all fittings as well as the hoses before operating the equipment,
- Check the hoses regularly; change them if they are damaged,
- Never exceed the maximum working pressure (MWP) indicated on the hose.

### USED PRODUCTS

Considering the wide variety of products that are available and can be used in our equipment it is impossible to check and make recommendations for all chemical data, regarding the risks of possible chemical attack and their long term chemical reaction

SAMES KREMLIN can not be held liable for :

- compatibility of wetted parts,
- risks to staff and the surroundings,
- for worn or defective parts, for faulty equipment or units, or the quality of final product.

It is the responsibility of the user to know and prevent any possible risks such as toxic vapours, fires or explosions. He shall determine the risks of immediate reactions or pursuant to repeated exposures of the staff,

SAMES KREMLIN shall not be liable for physical injuries, direct or indirect material damages caused by the use of chemicals.



## 2. HANDLING

 **Check the weight and the dimensions of the equipment**  
(☞ refer to 'Technical features' section of the instruction manual)

If weight and dimensions are too important, the unloading must be carried out by means of a forklift or any other appropriate means with a qualified personnel and in a clear horizontal area to prevent from risks of damage injury or an accident.

The centre of gravity is not in the centre of the machine : carry out by hand a stability-test after having lifted the whole at 10 cm / 3.937" maximum.

After the unloading, the handling of the whole (eg: elevator pump) is carried out by means of a pallet truck taking the bottom part of the frame.

**Remark : Each pump motor is fitted with a ring. The ring is designed for the hoisting of one pump and can not be used for the handling of the complete assembly.**

## 3. STORING

Storing before installation :

- Storing ambient temperature : 0 / +50 °C / 0 / +122°F
- Protect the whole against dust, water trickling, dampness and shocks.

Storing after installation :

- Operating temperature : +15 / +35 °C / +59 / +138.2° F
- Protect the whole against dust, water trickling, dampness and shocks.

## 4. INSTALLATION OF THE EQUIPMENT

The machine is installed on a stable horizontal floor (for eg a concrete flag).

The machine shall be made stable by the use of holding down bolts or by the use of other anchoring methods, strong enough to prevent unintended bodily movement of the equipment.



**To avoid risks caused by static electricity, the equipment as well as its components must be grounded.**

- **For the pumping equipments** (pumps, pneumatic rams, frame...), a section wire of 2.5 mm<sup>2</sup> is fixed on the material. Use this wire to connect the material to "the general ground". In case of severe environments (mechanical protection of the wire of earthing insufficient, vibrations, mobile material...) where function damages at the ground are probable, the user have to replace the provided wire of 2.5 mm<sup>2</sup> by a device more adapted to its environment (wire with a more important section, bonding strip, fixing by thimble with eyelet...).

The continuity of the ground must be controlled by a qualified electrician. If the continuity of the ground is not ensured, check the terminal, the wire and the earthing point. **Never** use the material without have solved this problem.

- In the severe cases of environments (mechanical protection of the wire of earthing insufficient, vibrations, mobile material...) where damages of the function put at the ground are probable, the user will have to replace the wire of 2.5 mm<sup>2</sup> provided, by a device more adapted to its environment (wire of more important section, bonding strip, fixing by thimble with eyelet...),
- **The gun** must be 'grounded' via a material hose or an air hose. In case of spraying by means of a gun with cup, the air hose must be conductive,
- **The materials to be painted** must also be grounded.

**All the materials situated in the working area shall be grounded.**



- **Never store** more than necessary inflammable materials inside the working area,
- The materials must be stored into **approved drums** and grounded,
- Use only grounded **metals containers** for the use of cleaning solvents,
- **Cardboard and paper are prohibited.**

## 5. MARKING OF THE EQUIPMENT



Each equipment has a label plate with the name of the manufacturer, the equipment part number, the interesting informations to use correctly the equipment (pressure, voltage,...) and sometimes the above pictogram.

The equipment is designed with and consists of high quality materials and components which can be re-used.

The 2012/19/UE European Directive covers all equipments with a crossed-out bin pictogram. Please inform yourself about the collection systems for electric and electronic equipments.

Please act in accordance with local rules and **do not dispose of old equipment with household wastes**. A correct disposal of old equipment will help prevent negative consequences for the environment and health.

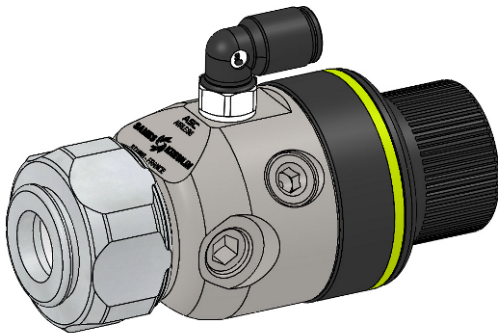

## AIRLESS AUTOMATIC GUN

***ASC 240 and ASC 400***

***Disassembly / Reassembly***

### TRANSLATION FROM THE ORIGINAL MANUAL

***IMPORTANT : Before assembly and start-up, please read and clearly understand all the documents relating to this equipment (professional use only).***

THE PICTURES AND DRAWINGS ARE NON CONTRACTUAL. WE RESERVE THE RIGHT TO MAKE CHANGES WITHOUT PRIOR NOTICE.

**SAMES KREMLIN SAS**

13, chemin de Malacher  
38 240 - MEYLAN - France

 : 33 (0)4 76 41 60 60

**[www.sames-kremlin.com](http://www.sames-kremlin.com)**



**CAUTION :**

Before any intervention on the gun, shut off the compressed air supply and depressurize the circuits controlling the opening of the gun.

**The gun is manufactured under the ATEX agreement and can not be modified. SAMES KREMLIN will not be held responsible for any failure to comply with that instruction.**

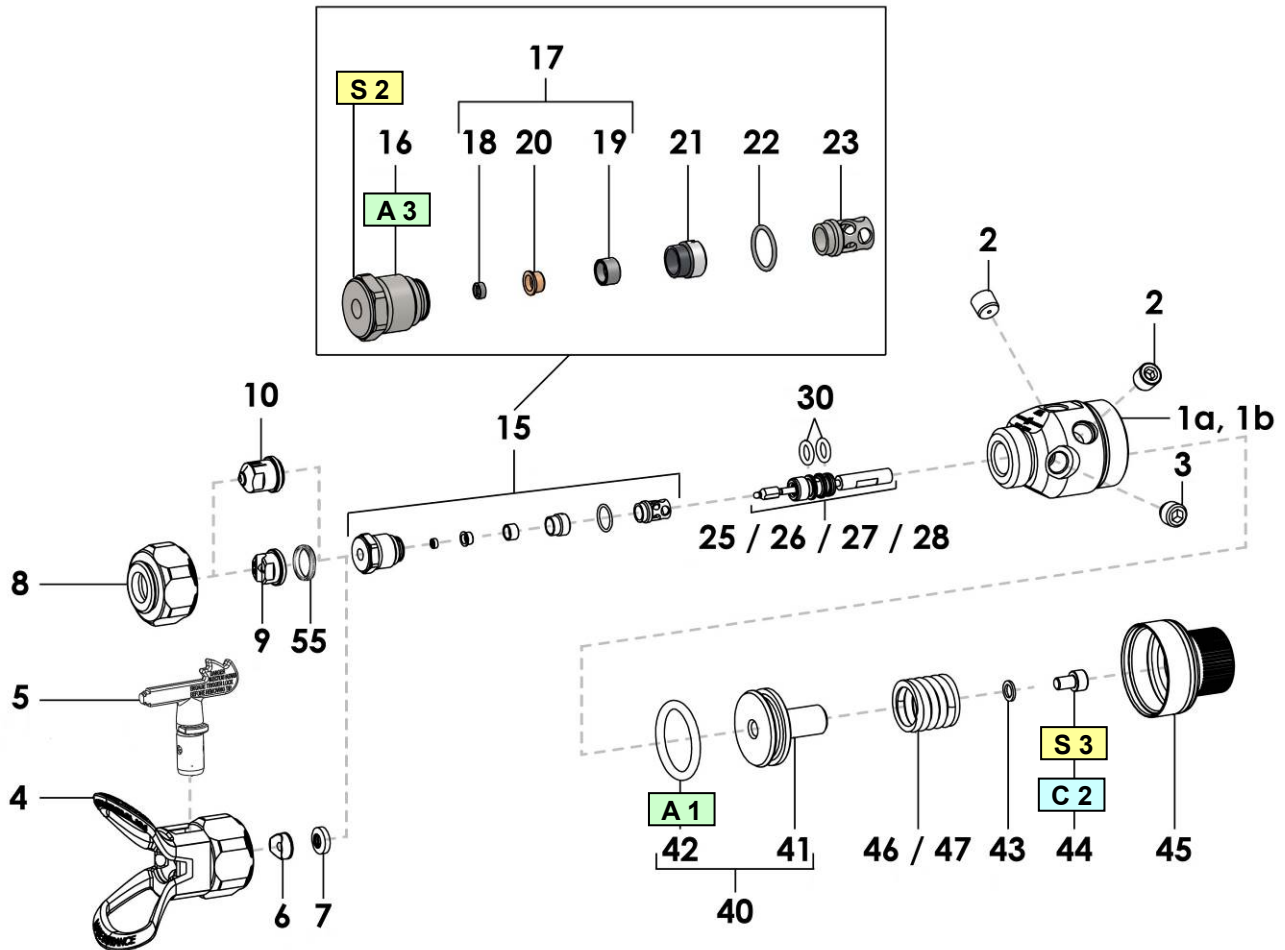

Index	Instructions	Description	Part number
<b>A 1</b>	PTFE grease	PTFE grease (10 ml / 0.0026 US gal)	560.440.101
<b>A 3</b>	Grease (vaseline)	-	-
<b>C 2</b>	Low strength - Anaerobic Adhesive	Loctite 222 (50 ml / 0.013 US gal)	554.180.010
<b>S 1</b>	Screwing torque : 2 Nm / 1.4752 Ft/Lbs		
<b>S 2</b>	Screwing torque : 10 Nm / 7.376 Ft/Lbs		
<b>S 3</b>	Screwing torque : 1 Nm / 0.7376 Ft/Lbs		

Before removing a component of the gun, some precautions have to be taken :

- Empty out the paint inside the cup or the receiver.
- Fill the cup or the receiver with cleaning solvent.
- Spray the solvent until it runs clear.
- Shut off the supply air pressure of the pump.
- Trigger the gun to depressurize the circuit.
- Shut off the supply air pressure of the gun.
- Remove the part to be cleaned or changed.

**Before reassembling the different components, some precautions must be taken :**

- **Clean all the parts with the appropriate cleaning solvent and a brush.**
- **Install new seals if it is necessary after having lubricated them with PTFE grease.**
- **Install new parts if it is necessary.**

#### ▪ SEAT HOLDER ASSEMBLY (IND. 15) REPLACEMENT

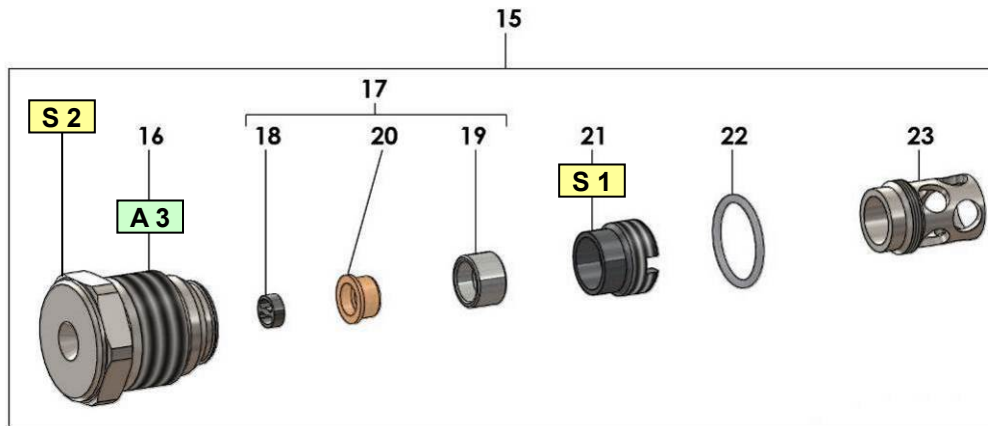

Remove the air cap, then unscrew the seat holder assembly (15) by means of the wrench supplied with the gun.

Loosen the cartridge stop (23) and the screw (21) by means of a screwdriver, take off the seat (19), the PEEK seal (20) and the helicoils (18).

Check parts' and the O-Ring (22) conditions. Change them if necessary.

Reassemble the seat (19), the PEEK seal (20) and the helicoils (18).

Tighten the screw (21) - Screwing torque : 2 Nm / 1.4752 Ft/Lbs.

Tighten the cartridge stop (23) manually.

Lubricate the seat holder thread (16) with grease.

Tighten the seat holder (15) in the gun by means of the wrench  
- Screwing torque : 10 Nm / 7.376 Ft/Lbs.

▪ **CARTRIDGE-NEEDLE ASSEMBLY (IND. 25, 26, 27 OR 28) DISASSEMBLY**

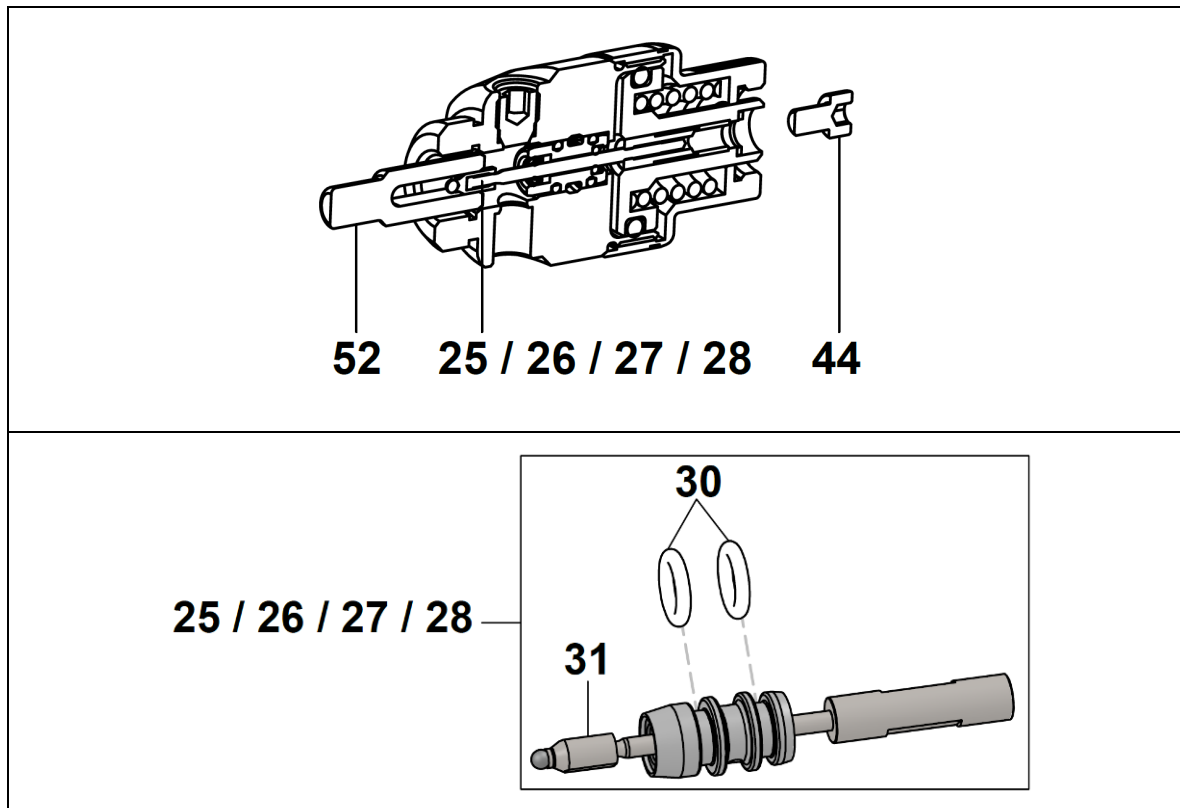

Unscrew handly the tightening nut (4 or 8)

Remove handly the tip (10) or (9) or the assembly (6 and 7).

Remove the cylinder (45).

Remove handly the spring (46 or 47).

Unscrew the seat holder assembly (15) with a 15mm wrench

Place handly the tool (52) onto the nozzle of the needle (31), maintain it and loosen the screw (44) with an Allen key size 4mm (50).

Remove handly the seal (43).

Remove the piston assembly (40).

To remove the cartridge-needle assembly (25, 26, 27 or 28), push on the needle shaft by sliding frontwards.

▪ CARTRIDGE-NEEDLE ASSEMBLY (IND. 25, 26, 27 OR 28) REASSEMBLY

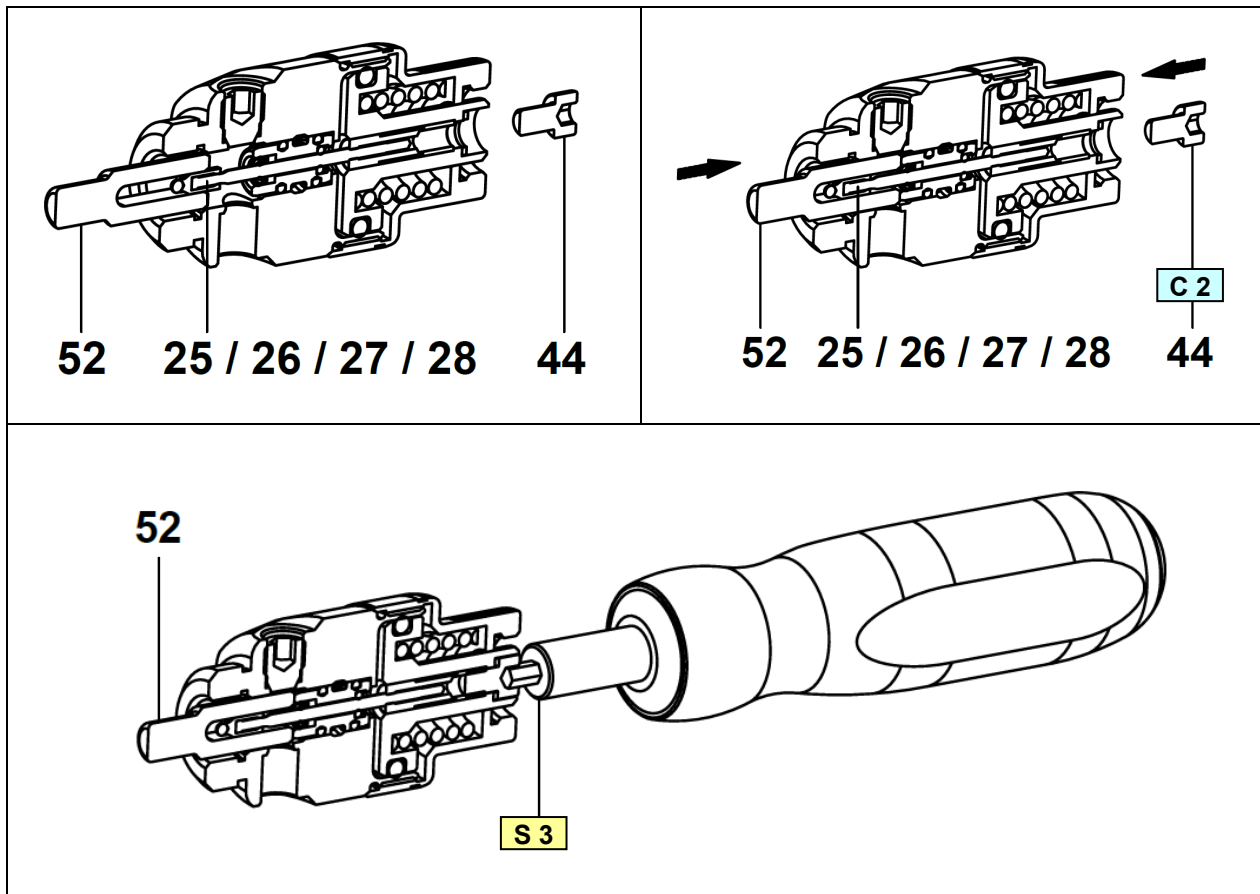

Grease the cartridge seals (30).

Place the new cartridge-needle assembly (25, 26, 27 or 28) in the gun with the tool (52) to the stop.

Grease the seal (42) and place the piston assembly (40).

Place the spring (46 or 47).

Place the cylinder (45) by placing the spring (46 or 47) into the groove of the cylinder.

Grease and place the seal (43).

Place the tool (52) onto the nozzle of the needle (31).

Hold handly the tool (52) onto the nozzle of the needle (31), Applicate glue on the screw (44) and lightly tighten it with a torque screwdriver (screwing torque 1Nm / 0.7376 Ft/Lbs).

**⚠ CAUTION : Please follow the instruction regarding the screwing torque (1 Nm / 0.7376 Ft/Lbs).**

Tighten the seat holder (15) in the gun by means of the wrench - Screwing torque : 10 Nm / 7.376 Ft/Lbs.

Place the tip (9) or (10) or the assembly (6 and 7).

Screw handly the tightening nut (4) or (8).

▪ **DISASSEMBLY OF THE TIPS**

**REVERSING TIPS (IND. 4, 5, 6, 7)**

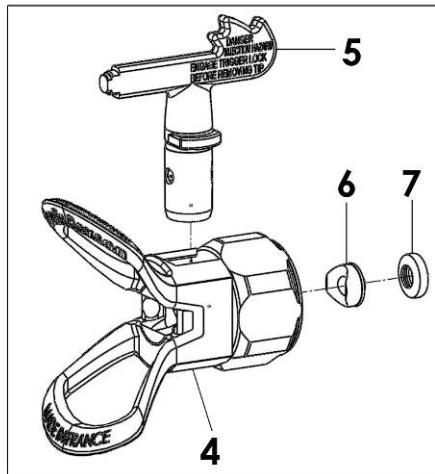

Untighten tightening nut.

Pivot the tip at 90 degrees angle from the horizontal axis and remove it upwards.

Remove the seat (6 & 7) by using the front part of the handle (5).

Clean and/or change the parts.

Install the seat (6) on the seal (7).

Insert and orientate the seat (6) and the seal (7) by using the front part of the handle (5).

Insert the handle (5) at 90 degree angle from the horizontal axis then pivot (flame downwards).

Install on the gun and tighten tightening nut.

**FLAT TIPS (IND. 8, 9)**

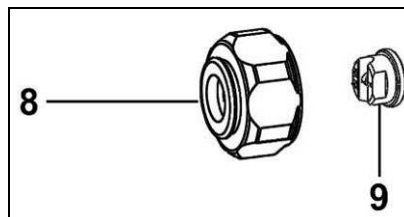

Untighten tightening nut.

Remove the tip (9) from tightening nut (8).

Reinstall the parts in the reverse order of the disassembly sequence.

**SKILL™ TIPS (IND. 8, 10)**

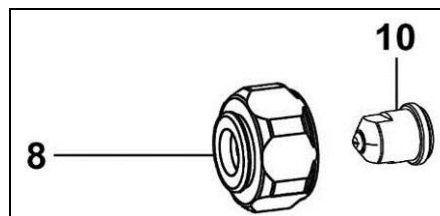

Untighten tightening nut.

Remove the tip (10) from tightening nut (8).

Reinstall the parts in the reverse order of the disassembly sequence.



▪ **QUICK FITS LUBRICANT RECIRCULATING (IND. 12) (ON REQUEST)**

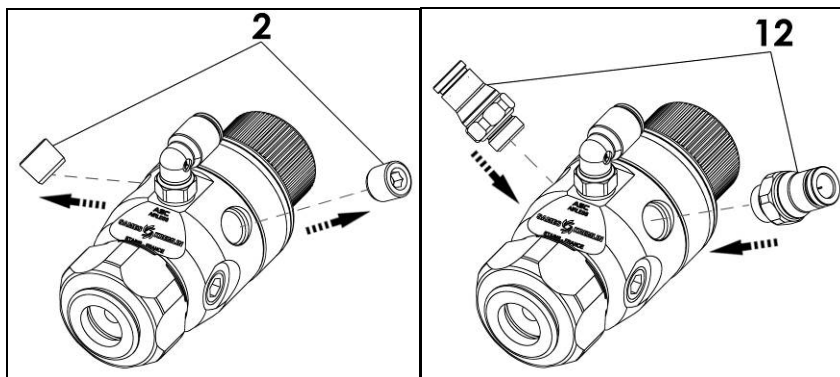

Unscrew and remove the plugs (2) with an Allen key size 4mm.  
Install the fits (12) with a flat wrench size 13mm.

▪ **FITTING PRODUCT MG1/8" - M1/2 JIC (IND. 83) (ON REQUEST)**

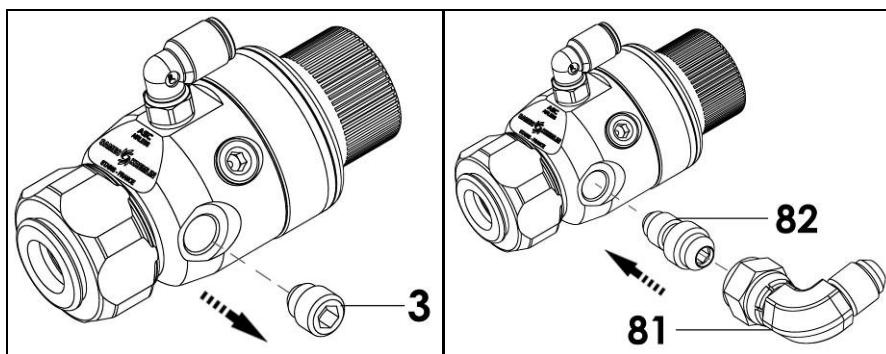

*Important : you can place the fitting on the two sides of the gun.*

Remove the male plug (3) with an Allen key size 4mm.  
Install the fitting product (82) into the gun body with an Allen key size 5mm.  
Place the elbow fitting (81) on the fitting product (82) with an adjustable wrench.

▪ **FITTING M1/4 NPS - F1/2 JIC (IND. 84) (ON REQUEST)**

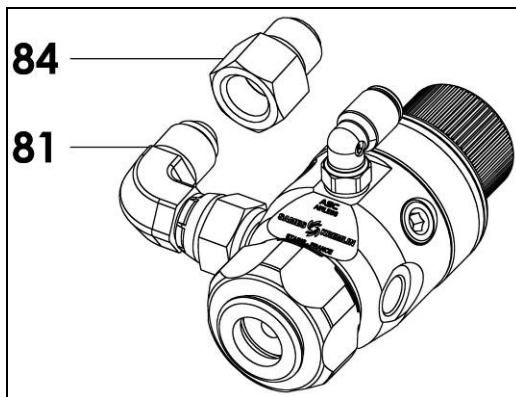

Install the fitting (84) on the elbow fitting (81) with a flat wrench size 17mm.

- **SCREEN (IND. 32 OR 33 OR 34) (ON REQUEST)**

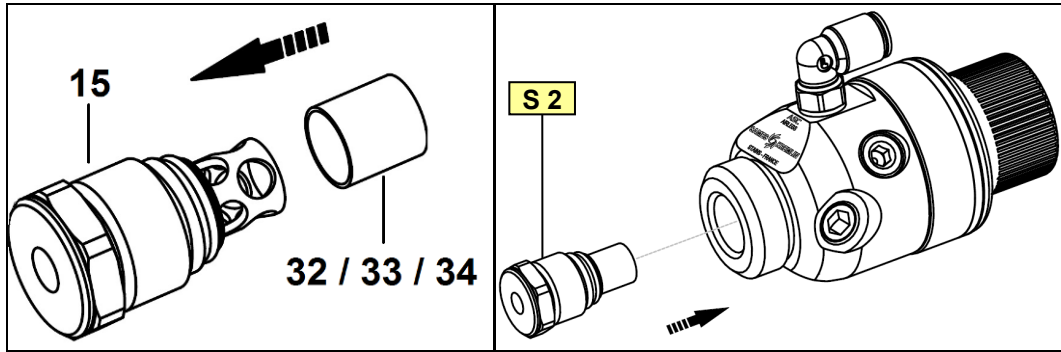

Install the screen n°4 (32) or n°6 (33) or n°12 (34) on the cartridge and stop of the seat holder assembly (15).

Place the assembly at the front of the body gun.

Tight the assembly with a torque wrench size 15mm - Screwing torque : 10 Nm / 7.376 Ft/Lbs.

- **MANIFOLD FOR 2 GUNS (IND. 35) (ON REQUEST)**

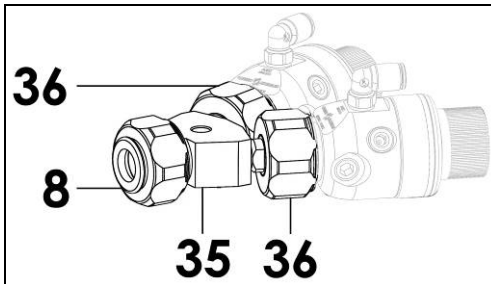

Replace the tightening nut (8) by the manifold for 2 guns (35).

- **MANIFOLD 1/2 JIC (IND. 36) (ON REQUEST)**

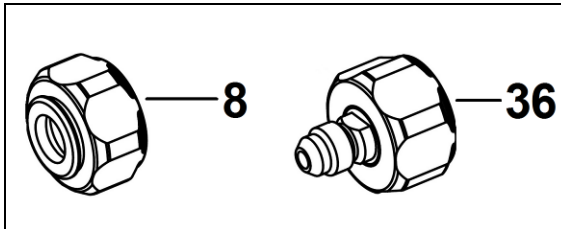

Replace the tightening nut (8) by the manifold 1/2 JIC (36).

▪ **HOLDING ROD (IND. 60) (ON REQUEST)**

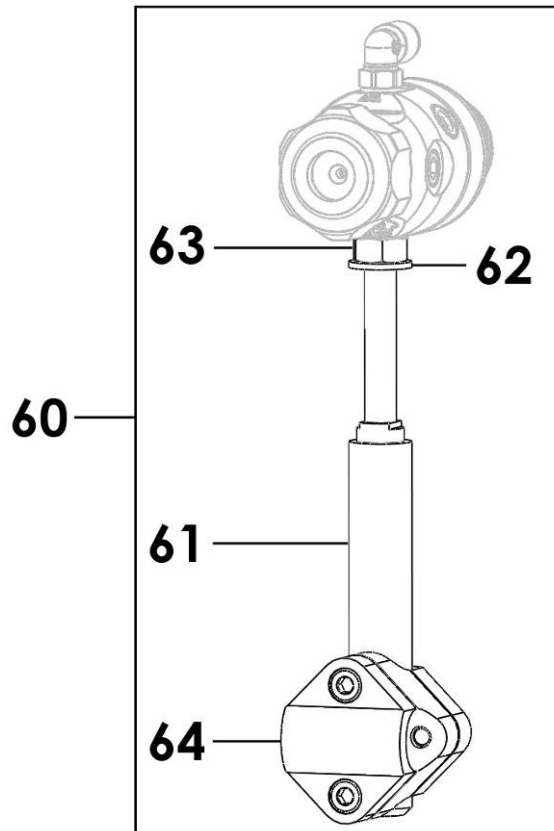

Place the holding rod (61) to the body gun.

Tighten the nut (63) with a flat wrench size 13 mm

Screw the 4 screws of the nut (64) with an Allen key size 4 mm.

▪ **MOUNTING SUPPORT (IND. 66) (ON REQUEST)**

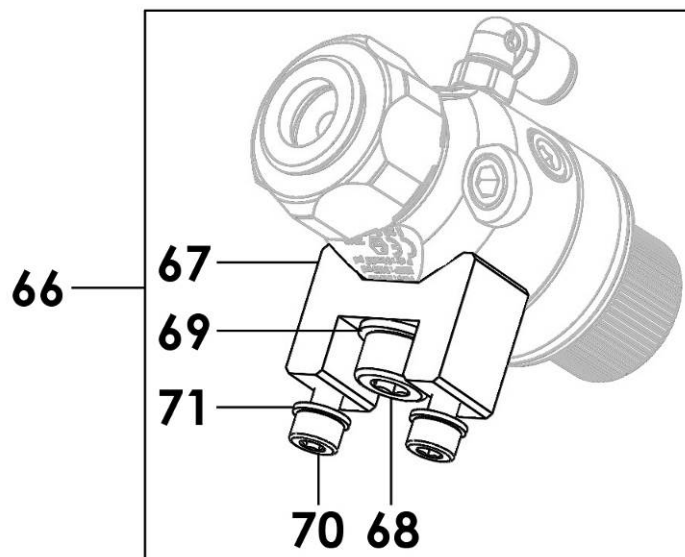

Place the support (66) on the body gun.

Screw the screw (68) with an Allen key size 6 mm.

Screw the 2 screws (70) with an Allen key size 4 mm.

- **CLOSING SUPPORT (IND. 65) (ON REQUEST)**

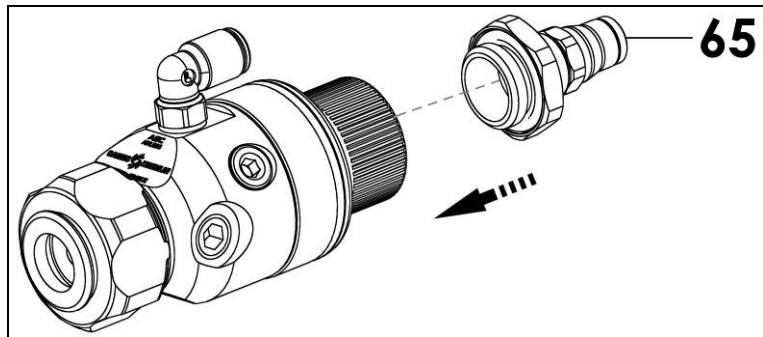

Place the closing support (65) to the back of the cover of the piston assembly and tight with a flat wrench size 24 mm..

- **GT CARTRIDGE - PEEK CARBIDE SEAT NEEDLE ASSEMBLY (IND. 27) (ON REQUEST)**

See CARTRIDGE-NEEDLE ASSEMBLY (ind. 25, 26, 27 or 28) and CARTRIDGE-NEEDLE ASSEMBLY (ind. 25, 26, 27 or 28) reassembly.

- **PTFE CARTRIDGE - PEEK CARBIDE SEAT NEEDLE ASSEMBLY (IND. 28) (ON REQUEST)**

See CARTRIDGE-NEEDLE ASSEMBLY (ind. 25, 26, 27 or 28) and CARTRIDGE-NEEDLE ASSEMBLY (ind. 25, 26, 27 or 28) reassembly

- **MANIFOLD REVERSING TIPS (IND. 4,5,6,7) (ON REQUEST)**

See DISASSEMBLY OF THE TIPS.

<p><b>Doc. 573.519.050</b> Date/Datum/Fecha : 27/11/18 Annule/Cancel/Ersetzt/Anula :</p>	<p>Modif. / Änderung :</p>	<p>Pièces de rechange Spare parts list Ersatzteilliste Piezas de repuesto</p>
--	----------------------------	---

<p><b>ASC</b> <b>240 / 400</b></p>	<p><b>PISTOLET AUTOMATIQUE AIRLESS® AVEC BAGUE, sans buse</b>  <b>AIRLESS SPRAY GUN WITH MANIFOLD, without tip</b>  <b>AUTOMATISCHE AIRLESS-SPRITZPISTOLE MIT DÜSENAUFNAHME, ohne Düse</b>  <b>PISTOLA AUTOMÁTICA AIRLESS CON ANILLO, sin boquilla</b></p>
--	--

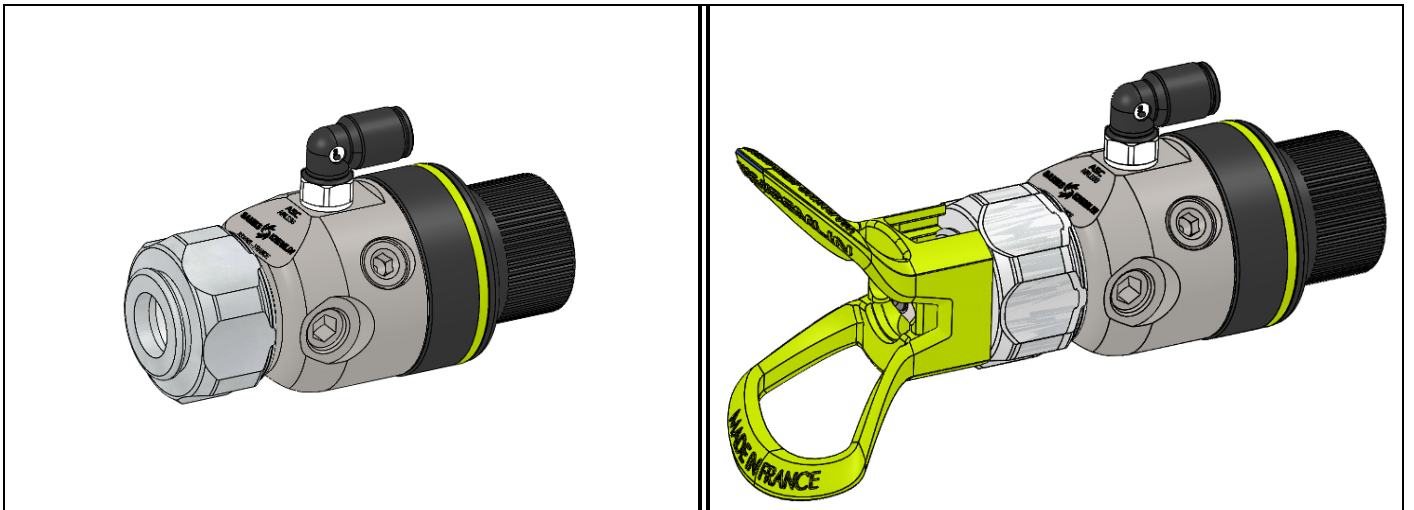

	<b>ASC</b>	<p><b>A</b> Pistolet / Gun / Pistole / Pistola</p>
	<p><b>B</b> Raccords / Fittings / Anschlüsse / Racores</p>	
<p><b>C</b> Ecrou de serrage / Tightening nut / Überwurfmutter / Tuerca de apriete</p>		
<p><b>D</b> Buse AIRLESS® / AIRLESS Tip / AIRLESS-Düse / Boquilla AIRLESS</p>		

<b>A</b>	<b>PISTOLET / GUN / PISTOLE / PISTOLA (inox / stainless steel / Edelstahl)</b>
----------	--

Pistolet automatique, type ASC 240 Airless® avec écrou de serrage pour buse plate et Skill™, sans buse avec cartouche PTFE	Airless automatic spray gun, model ASC 240 Airless with tightening nut for flat and Skill™ tip, without tip, with PTFE cartridge	#
Automatische ASC 240 Airless -Spritzpistole mit Überwurfmutter für Standard- und Skill™-Düsen, ohne Düse, mit Packung PTFE	Pistola automática, tipo ASC 240 Airless con tuerca de apriete para boquilla plana y Skill™, sin boquilla con cartucho PTFE	129.982.121

Pistolet automatique, type ASC 240 Airless® avec écrou de serrage pour buse réversible, sans buse avec cartouche PTFE	Airless automatic spray gun, model ASC 240 Airless with tightening nut for reversing tip, without tip with PTFE cartridge	#
Automatische ASC 240 Airless -Spritzpistole mit Überwurfmutter für Wendedüse ohne Düse mit Packung PTFE	Pistola automática, tipo ASC 240 Airless con tuerca de apriete para boquilla reversible, sin boquilla con cartucho PTFE	129.982.122

Pistolet automatique, type ASC 240 Airless® avec écrou de serrage pour buse plate et Skill™, sans buse avec cartouche GT	Airless automatic spray gun, model ASC 240 Airless with tightening nut for flat and Skill™ tip, without tip, with GT cartridge	#
Automatische ASC 240 Airless -Spritzpistole mit Überwurfmutter für Standard- und Skill™-Düsen, ohne Düse, mit Packung GT	Pistola automática, tipo ASC 240 Airless con tuerca de apriete boquilla plana y Skill™, sin boquilla con cartucho GT	129.982.521

<b>Pistolet automatique, type ASC 240 Airless® avec écrou de serrage pour buse réversible, sans buse avec cartouche GT</b>	<b>Airless automatic spray gun, model ASC 240 Airless with tightening nut for reversing tip, without tip, with GT cartridge</b>	<b>#</b>
<b>Automatische ASC 240 Airless -Spritzpistole mit Überwurfmutter für Wendedüse, ohne Düse, mit Packung GT</b>	<b>Pistola automática, tipo ASC 240 Airless con tuerca de apriete para boquilla reversible sin boquilla con cartucho GT</b>	<b>129.982.522</b>

<b>Pistolet automatique, type ASC 400 Airless® avec écrou de serrage pour buse plate et Skill™, sans buse avec cartouche PTFE</b>	<b>Airless automatic spray gun, model ASC 400 Airless with tightening nut for flat and Skill™ tip, without tip, with PTFE cartridge</b>	<b>#</b>
<b>Automatische ASC 400 Airless -Spritzpistole mit Überwurfmutter für Standard- und Skill™-Düsen, ohne Düse, mit Packung PTFE</b>	<b>Pistola automática, tipo ASC 400 Airless con tuerca de apriete para boquilla plana y Skill™, sin boquilla con cartucho PTFE</b>	<b>129.984.121</b>

<b>Pistolet automatique, type ASC 400 Airless® avec écrou de serrage pour buse réversible, sans buse avec cartouche PTFE</b>	<b>Airless automatic spray gun, model ASC 400 Airless with tightening nut for reversing tip, without tip with PTFE cartridge</b>	<b>#</b>
<b>Automatische ASC 400 Airless -Spritzpistole mit Überwurfmutter für Wendedüse ohne Düse mit Packung PTFE</b>	<b>Pistola automática, tipo ASC 400 Airless con tuerca de apriete para boquilla reversible, sin boquilla con cartucho PTFE</b>	<b>129.984.122</b>

<b>Pistolet automatique, type ASC 400 Airless® avec avec écrou de serrage pour buse plate et Skill™, sans buse avec cartouche GT</b>	<b>Airless automatic spray gun, model ASC 400 Airless with tightening nut for flat and Skill™ tip, without tip, with GT cartridge</b>	<b>#</b>
<b>Automatische ASC 400 Airless -Spritzpistole mit Überwurfmutter für Standard- und Skill™-Düsen, ohne Düse, mit Packung GT</b>	<b>Pistola automática, tipo ASC 400 Airless con tuerca de apriete para boquilla plana y Skill™, sin boquilla con cartucho GT</b>	<b>129.984.521</b>

<b>Pistolet automatique, type ASC 400 Airless® avec écrou de serrage pour buse réversible, sans buse avec cartouche GT</b>	<b>Airless automatic spray gun, model ASC 400 Airless with tightening nut for reversing tip, without tip, with GT cartridge</b>	<b>#</b>
<b>Automatische ASC 400 Airless -Spritzpistole mit Überwurfmutter für Wendedüse, ohne Düse, mit Packung GT</b>	<b>Pistola automática, tipo ASC 400 Airless con tuerca de apriete para boquilla reversible sin boquilla con cartucho GT</b>	<b>129.984.522</b>

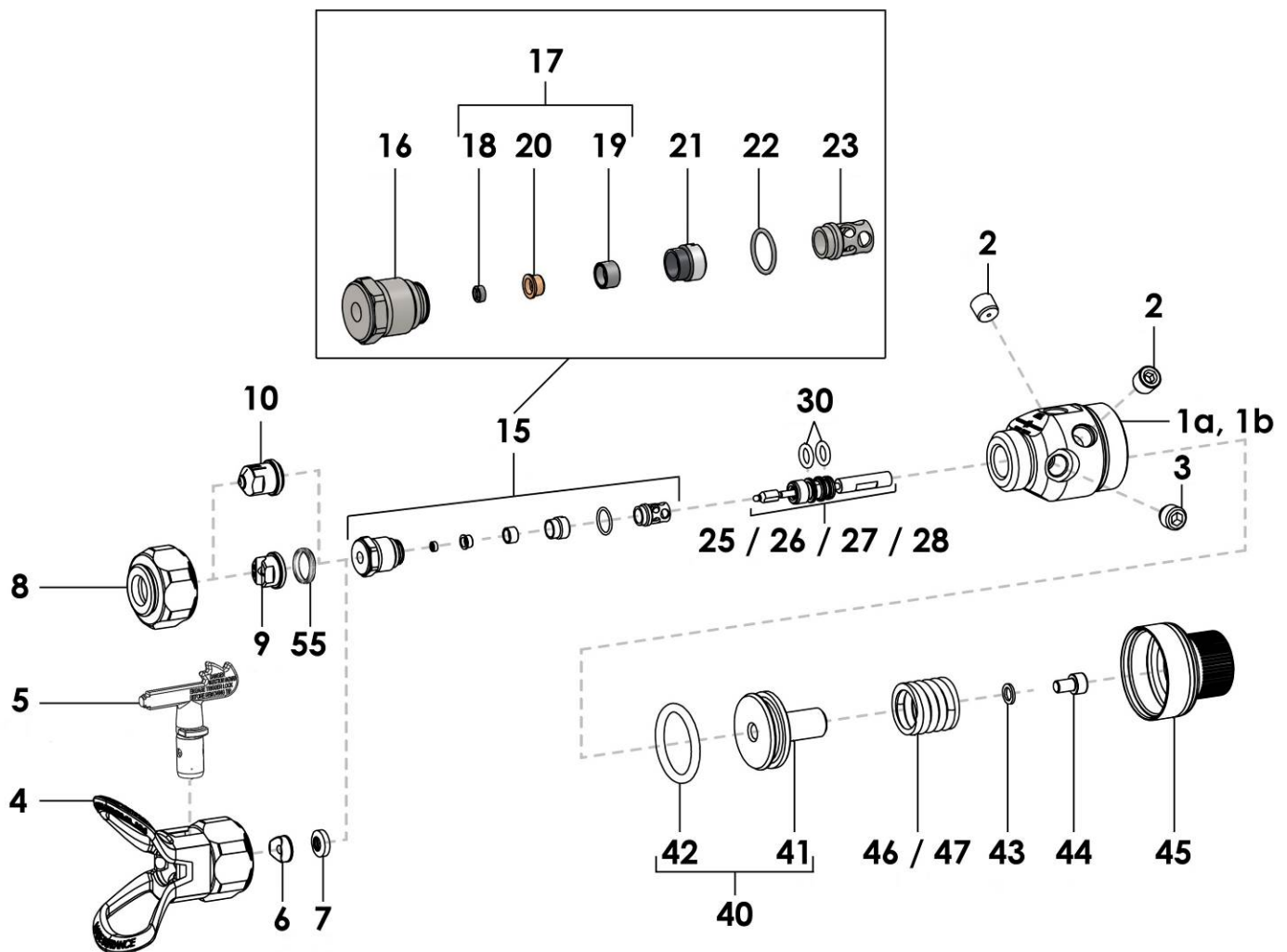



**Pièces communes - Common parts - Gleiche Teile - Partes comunes**

Ind	#	Désignation	Description	Bezeichnung	Denominación	Qté
2	129 990 029	Bouchon G 1/8 percé (x2)	Plug, model G 1/8 (x2)	Blindstopfen G 1/8 (x2)	Tapón, tipo G 1/8 (x2)	2
3	129 982 001	Bouchon mâle	Male plug	Blindstopfen	Tapón macho	1
<b>*15</b>	<b>129 740 040</b>	<b>Porte siège assemblé</b>	<b>Seat holder assembly</b>	<b>Düsennadelsitz Einheit</b>	<b>Porta asiento equipado</b>	<b>1</b>
16	NC / NS	▪ Porte siège	▪ Seat holder	▪ Düsennadelsitz	▪ Porta asiento	1
*17	129 740 908	▪ Siège avec joint PEEK (x2)	▪ Seat with PEEK seal (x2)	▪ Sitz mit Dichtung - PEEK (x2)	▪ Asiento con junta, PEEK (x2)	1
18	NC / NS	▪ ▪ Pastille (x2)	▪ ▪ Helicoils (x2)	▪ ▪ Begrenzer (x2)	▪ ▪ Helicoil (x2)	1
19	129 670 049	▪ ▪ Siège carbure (x2)	▪ ▪ Seat carbide (x2)	▪ ▪ Sitz Hartmetall (x2)	▪ ▪ Asiento carburo (x2)	1
20	NC / NS	▪ ▪ Joint PEEK (x2)	▪ ▪ PEEK seal (x2)	▪ ▪ Dichtung-PEEK (x2)	▪ ▪ Junta PEEK (x2)	1
21	029 600 106	▪ Vis pour siège	▪ Screw for seat	▪ Schraube	▪ Tornillo para asiento	1
*22	150 040 341	▪ Joint torique (x10)	▪ O-Ring (x10)	▪ O-Ring (x10)	▪ Junta tórica (x10)	1
*23	129 740 045	▪ Butée de cartouche (x5)	▪ Cartridge stop (x5)	▪ Anschlag für Packung (x5)	▪ Tope de cartucho (x5)	1
<b>*40</b>	<b>129 982 045</b>	<b>Piston équipé</b>	<b>Piston assembly</b>	<b>Kolben, kpl.</b>	<b>Pistón equipado</b>	<b>1</b>
41	NC / NS	▪ Piston	▪ Piston	▪ Kolben	▪ Pistón	1
42	909 130 522	▪ Joint de piston	▪ Piston seal	▪ Dichtung	▪ Junta de pistón	1
*43	NC / NS	Joint	Seal	Dichtung	Junta	1
44	88 127	Vis, type CHc M 5x8	Screw, model CHc M 5x8	Schraube CHc M 5x8	Tornillo, tipo CHc M 5x8	1
45	129 982 041	Cylindre	Cylinder	Materialzylinder	Cilindro	1

**Pièces spécifiques - Specific parts - Spezifische Teile - Partes específicas**

Ind	#	Désignation	Description	Bezeichnung	Denominación	Qté
1a	NC / NS	Corps pistolet 240 bar	Gun body 240 bar	Pistolenkörper 240 bar	Cuerpo pistola 240 bar	1
1b	NC / NS	Corps pistolet 400 bar	Gun body 400 bar	Pistolenkörper 400 bar	Cuerpo pistola 400 bar	1
4	-	Ecrou de serrage pour buse réversible TIP TOP (voir accessoires)	Tightening nut for reversing TIP TOP (refer to accessories)	Überwurfmutter für Wende-Düse TIP TOP (siehe Zubehör)	Tuerca de presión para boquilla reversible TIP TOP (consultar accesorios)	1
5+6 +7	-	Buse Airless® réversible TIP TOP + siège + joint de buse (voir accessoires)	Reversing Airless TIP TOP + seat + seal tip (refer to accessories)	Airless Wende-Düse TIP TOP + Sitz + Düsendichtung (siehe Zubehör)	Boquilla Airless reversible TIP TOP + asiento + junta de boquilla (consultar accesorios)	1
8	-	Ecrou de serrage pour buse plate et buse Skill™ (voir accessoires)	Tightening nut for flat and Skill™ tip (refer to accessories)	Überwurfmutter für Standard- und Skill™-Düsen (siehe Zubehör)	Tuerca de presión para boquilla plana y boquilla Skill™ (consultar accesorios)	1
9	-	Buse Airless® (voir accessoires)	Airless tip (refer to accessories)	Airless Standard-Düse (siehe Zubehör)	Boquilla Airless reversible (consultar accesorios)	1
10	-	Buse Skill™ (voir accessoires)	Skill™ tip (refer to accessories)	Airless Skill™ Düse (siehe Zubehör)	Boquilla Skill™ (refer to accessories)	1

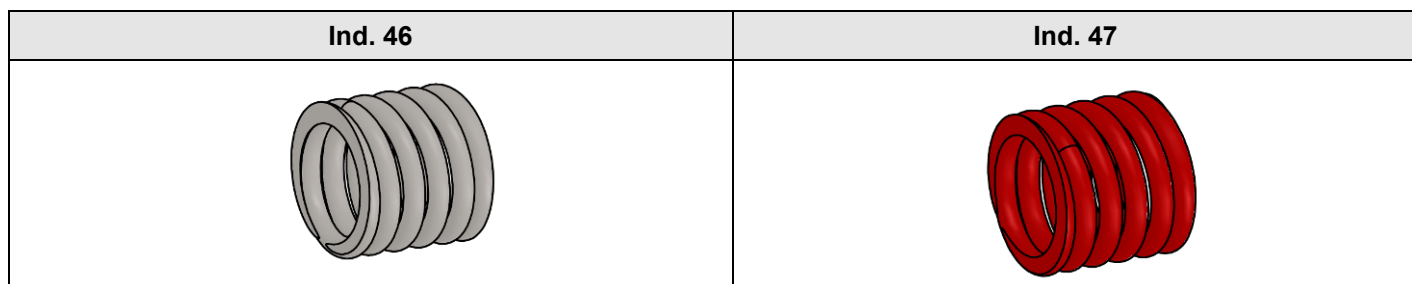

Ind	#	Désignation	Description	Bezeichnung	Denominación	Qté
46	150 314 106	Ressort de piston ASC 240 bar	Piston spring ASC 240 bar	Kolbenfeder ASC 240 bar	Muelle de pistón ASC 240 bar	1
47	150 314 107	Ressort de piston ASC 400 bar	Piston spring ASC 400 bar	Kolbenfeder ASC 400 bar	Muelle de pistón ASC 400 bar	1

**Ind. 25**

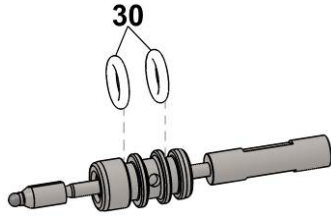

**Mod. Pointeau carbure - cartouche GT / GT cartridge-carbide needle  
/ Hartmetall Farbnadel mit Packung GT komplett / Aguja carburo-cartucho GT**

Ind	#	Désignation	Description	Bezeichnung	Denominación	Qté
*25	129 990 040	Ensemble pointeau carbure - cartouche GT	GT cartridge-carbide needle assembly	Hartmetall Farbnadel mit GT Packung komplett	Conjunto aguja carburo -cartucho GT	1
*30	129 990 063	▪ Joints FFKM (x10)	▪ Seal FFKM (x10)	▪ O-Ring, FFKM (x10)	▪ Junta FFKM (x10)	1
*52	129 990 034	▪ Outillage	▪ Tool	▪ Werkzeug	▪ Herramienta	1

**Ind. 26**

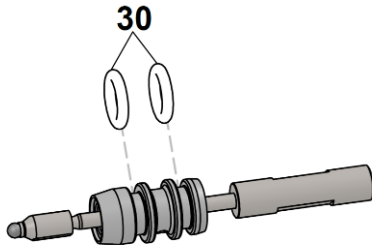

**Mod. Pointeau carbure - cartouche PTFE / PTFE cartridge-carbide needle  
/ Farbnadel mit Packung PTFE komplett / Aguja-cartucho PTFE**

Ind	#	Désignation	Description	Bezeichnung	Denominación	Qté
*26	129 990 050	Ensemble pointeau carbure - cartouche PTFE	PTFE cartridge-carbide needle assembly	Hartmetall Farbnadel mit PTFE Packung komplett	Conjunto aguja carburo cartucho PTFE	1
*30	129 990 063	▪ Joints FFKM (x10)	▪ Seal FFKM (x10)	▪ O-Ring, FFKM (x10)	▪ Junta FFKM (x10)	1
*52	129 990 034	▪ Outillage	▪ Tool	▪ Werkzeug	▪ Herramienta	1

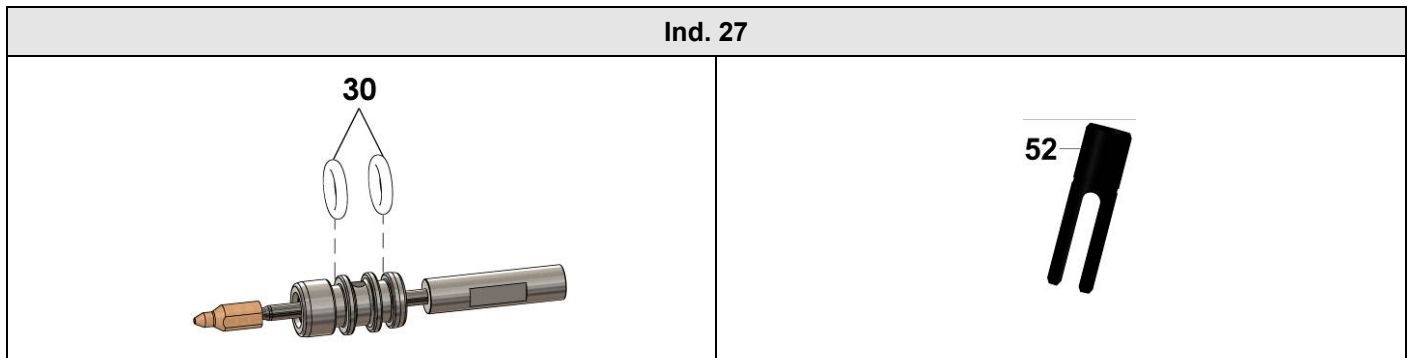

**Mod. Pointeau PEEK - cartouche GT / GT cartridge - PEEK needle  
/ Farbnadel PEEK mit Packung GT komplett / Aguja PEEK - cartucho GT**

Ind	#	Désignation	Description	Bezeichnung	Denominación	Qté
*27	129 990 080	Ensemble pointeau PEEK - cartouche GT	GT cartridge – PEEK needle assembly	Farbnadel PEEK mit GT Packung komplett	Conjunto aguja PEEK - cartucho GT	1
*30	129 990 063	▪ Joints FFKM (x10)	▪ Seal FFKM (x10)	▪ O-Ring, FFKM (x10)	▪ Junta FFKM (x10)	1
*52	129 990 034	▪ Outillage	▪ Tool	▪ Werkzeug	▪ Herramienta	1

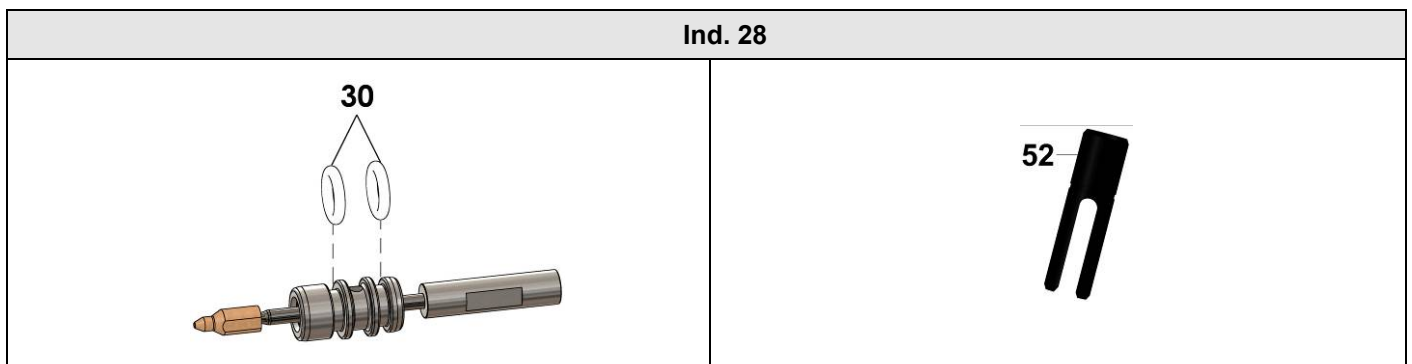

**Mod. Pointeau PEEK - cartouche PTFE / PTFE cartridge - PEEK Needle  
/ Farbnadel PEEK mit Packung PTFE komplett / Aguja PEEK - cartucho PTFE**

Ind	#	Désignation	Description	Bezeichnung	Denominación	Qté
*28	129 990 070	Ensemble pointeau PEEK - cartouche PTFE	PTFE cartridge – PEEK needle assembly	Farbnadel PEEK mit PTFE Packung komplett	Conjunto aguja PEEK - cartucho PTFE	1
*30	129 990 063	▪ Joints FFKM (x10)	▪ Seal FFKM (x10)	▪ O-Ring, FFKM (x10)	▪ Junta FFKM (x10)	1
*52	129 990 034	▪ Outillage	▪ Tool	▪ Werkzeug	▪ Herramienta	1

**POCHETTES - KITS - SÄTZE - BOLSAS**

Ind	#	Désignation	Description	Bezeichnung	Denominación	Qté
*	129 982 093	Pochette de joints (ind., 22, 30(x2), 42, 43)	Package of seals (ind., 22, 30(x2), 42, 43)	Dichtungssatz (Pos., 22, 30(x2), 42, 43)	Bolsa de juntas (ind., 22, 30(x2), 42, 43)	1

**B**

**RACCORDS - FITTINGS - ANSCHLÜSSE - RACORES**

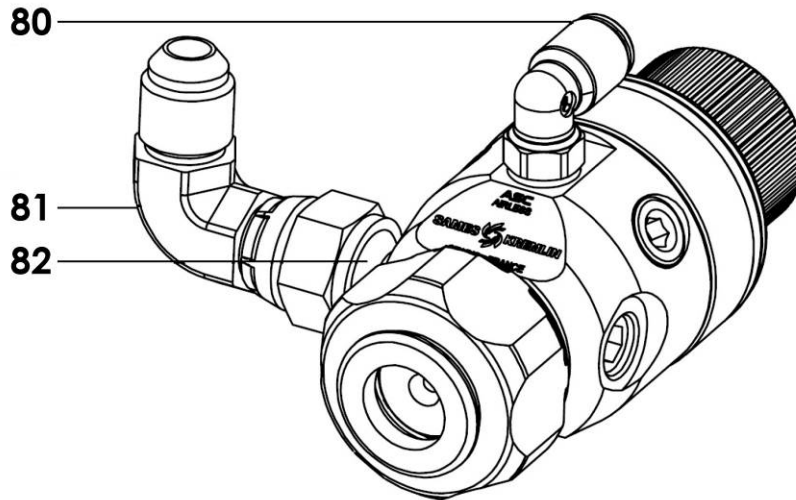

Ind	#	Désignation	Description	Bezeichnung	Denominación	Qté
80	905 120 902	Raccord coudé (commande) 1/8 G - 4x6	Elbow fitting (control) 1/8 G - 4x6	Winkelnippel (Steuerluft) 1/8 G - 4x6	Racor acodado (mando) 1/8 G - 4x6	1
81	905 160 101	Raccord produit coudé M1/2 JIC- F1/2 JIC	Elbow fitting (product) M1/2 JIC- F1/2 JIC	Winkelnippel AG1/2 JIC- IG1/2 JIC	Racor acodado M1/2 JIC- H1/2 JIC	1
82	129 982 003	Raccord produit MG1/8 - M1/2 JIC	Fitting (product) MG1/8 - M1/2- JIC	Nippel MG1/8 - AG1/2 - JIC	Racor producto MG1/8 - M1/2 - JIC	1

**OUTILS - TOOLS - WERKZEUG - HERRAMIENTA**

Ind	#	Désignation	Description	Bezeichnung	Denominación	Qté
50	921 080 301	Clé Allen 4mm	Allen key size 4mm	4er Inbusschlüssel	Llave Allen de 4mm	1
51	906 300 101	Goupillon	Large size brush	Reinigungsbürste, groß	Cepillo grande	1

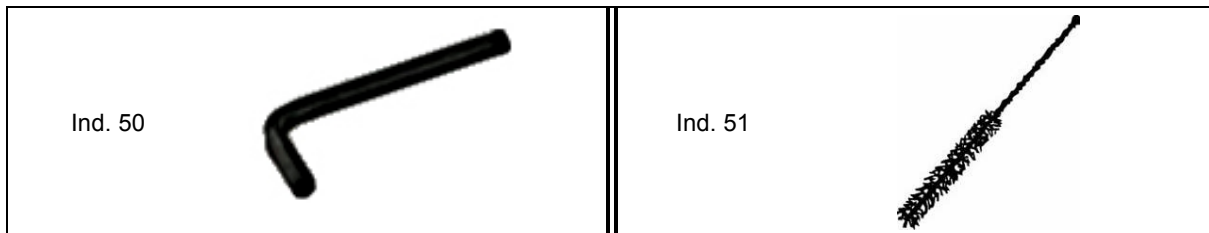

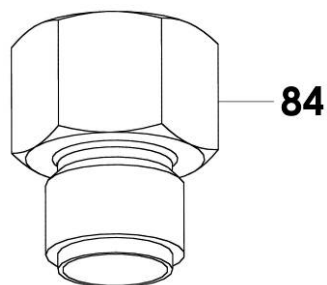
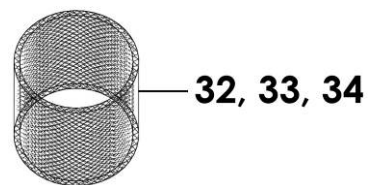
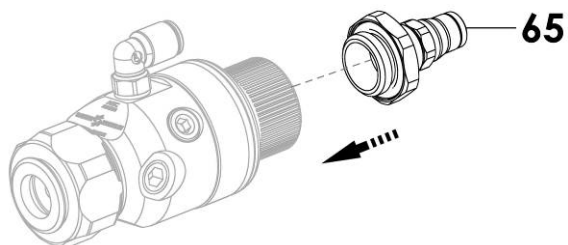
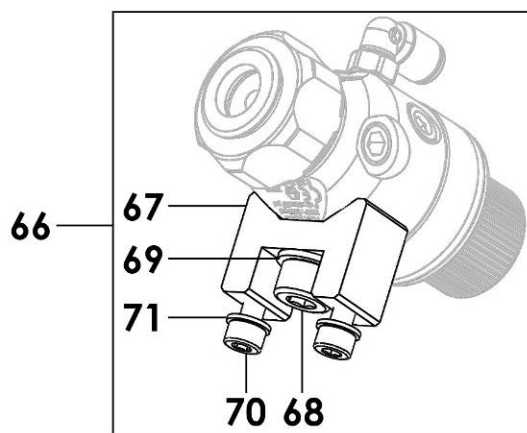
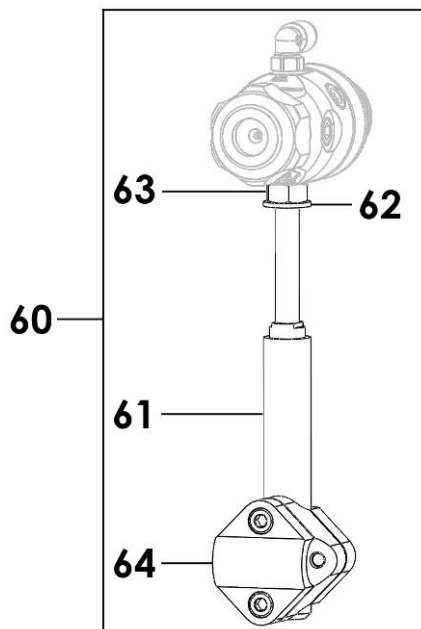
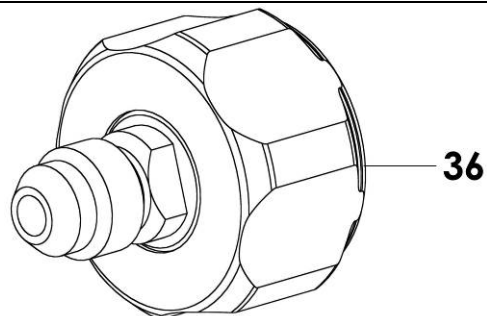
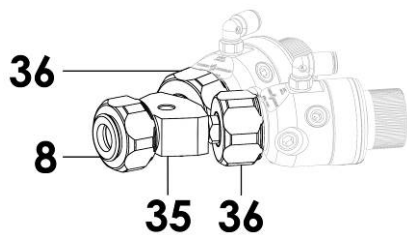

Ind	#	Désignation	Description	Bezeichnung	Denominación	Qté
32	129 982 021	Tamis n°4 (x5)	N°4 Screen (x5)	Sieb, Größe 4 (x5)	Tamiz de 4 (x5)	1
33	129 982 022	Tamis n°6 (x5)	N°6 Screen (x5)	Sieb, Größe 6 (x5)	Tamiz de 6 (x5)	1
34	129 982 023	Tamis n°12 (x5)	N°12 Screen (x5)	Sieb, Größe 12 (x5)	Tamiz de 12 (x5)	1
35	129 982 060	Manifold pour 2 pistolets	Manifold for 2 guns	Anschluss für 2 Pistolen	Boquilla para 2 pistolas	1
36	129 982 065	Tête 1/2 JIC	Manifold 1/2 JIC	Düsenaufnahme 1/2 JIC	Anillo para boquilla 1/2 JIC	1
<b>60</b>	<b>049 351 000</b>	<b>Tige de maintien</b>	<b>Holding rod</b>	<b>Pistolen Haltestange</b>	<b>Eje de sujeción</b>	<b>1</b>
61	049 351 001	▪ Tige	▪ Rod	▪ Stange	▪ Eje	1
62	963 020 019	▪ Rondelle ZU 8	▪ Washer, model ZU 8	▪ Scheibe ZU 8	▪ Arandela, tipo ZU 8	1
63	953 010 019	▪ Ecrou HM8	▪ Nut, model HM8	▪ Mutter, HM8	▪ Tuerca, tipo M8	1
64	906 480 002	▪ Noix	▪ Nuts	▪ Klemmstück	▪ Tuerca	1
65	129 982 050	Assistance fermeture 4x6	Closing support 4x6	Schließhilfe 4x6	Cierre 4x6	1
<b>66</b>	<b>129 982 030</b>	<b>Support de fixation</b>	<b>Mounting support</b>	<b>Pistolen Halterung</b>	<b>Soporte de fijación</b>	<b>1</b>
67	029 982 031	▪ Support	▪ Support	▪ Halterung	▪ Soporte	1
68	930 151 198	▪ Vis, type CHc M 8x16	▪ Screw, model CHc M 8x16	▪ Schraube, CHc M 8x16	▪ Tornillo, tipo CHc M 8x16	1
69	963 020 019	▪ Rondelle ZU 8	▪ Washer, model ZU 8	▪ Mutter, ZU 8	▪ Arandela, tipo ZU 8	1
70	931 151 168	▪ Vis, type CHc M 5x12	▪ Screw, model CHc M 5x12	▪ Schraube, CHc M 5x12	▪ Tornillo, tipo CHc M 5x12	2
71	963 040 014	▪ Rondelle Z M 5x10	▪ Washer, model Z M 5x10	▪ Mutter, Z M 5x10	▪ Arandela, tipo Z M 5x10	2
84	050 123 304	Raccord M1/4 NPS - F1/2 JIC	Fitting M1/4 NPS - F1/2 JIC	Nippel AG 1/4 NPS - IG 1/2 JIC	Racor M1/4 NPS - H1/2 JIC	1

**OPTION - ON REQUEST - OPTIONEN - OPCIÓN**

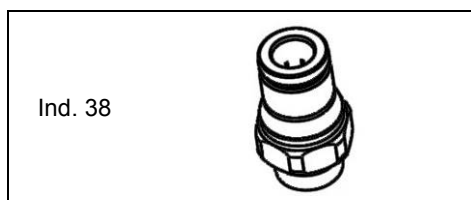

Ind	#	Désignation	Description	Bezeichnung	Denominación	Qté
*38	129 990 062	Raccord (x2)	Fitting (x2)	Nippel (x2)	Racor (x2)	1

**BUSES REVERSIBLES - REVERSING TIPS - WENDEÜSEN - BOQUILLAS REVERSIBLES**

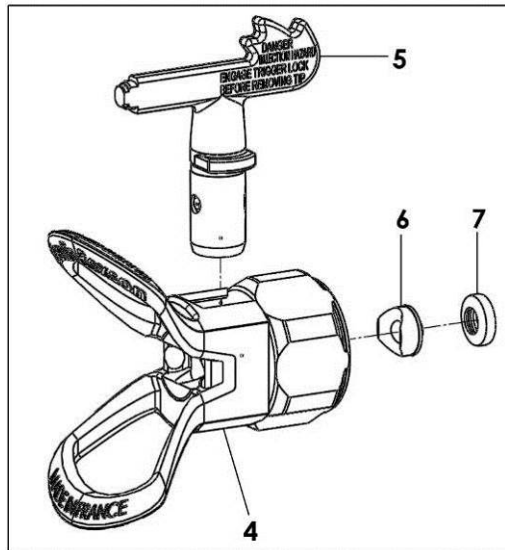

Ind	#	Désignation	Description	Bezeichnung	Denominación	Qté
4	132 740 200	Ecrou de serrage pour buse réversible TIP TOP (voir accessoires)	Tightening nut for reversing TIP TOP (refer to accessories)	Überwurfmutter für Wende-Düse TIP TOP (siehe Zubehör)	Tuerca de presión para boquilla reversible TIP TOP (consultar accesorios)	1
5+6 +7	000 40x xxx	Buse Airless® réversible TIP TOP + siège + joint de buse	Reversing Airless TIP TOP + seat + seal tip	Airless Wende-Düse TIP TOP + Sitz + Düsendichtung	Boquilla Airless® reversible TIP TOP + asiento + junta de boquilla	1
*7	134 740 007	Joint de buse réversible (x10)	Reversing seal tip (x10)	Düsendichtung (x10)	Junta de boquilla reversible (x10)	1

Ind	#	Désignation	Description	Bezeichnung	Denominación	Qté
*	129 740 907	Pochette de maintenance - siège + joint de buse (ind. 6 (x 4), 7 (x 4))	Servicing kit - seat + seal tip (ind. 6 (x 4), 7 (x 4))	Wartungssatz - Sitz + Düsendichtung (Pos. 6 (4 St.), 7 (4 St.))	Bolsa de reparación - asiento + junta de boquilla (ind. 6 (x 4), 7 (x 4))	1



**TABLEAU DES BUSES - TIP CHART - DÜSENTABELLE - CUADRO DE LAS BOQUILLAS**

Largeur de jet / Fan width / Strahlbreite / Anchura abanico →		12 / 16 cm	17 / 21 cm	22 / 24.5 cm	25 / 29 cm	29 / 33 cm	33 / 37 cm	38 / 44 cm	
Angle / Winkel / Abanico →		20°	30°	40°	50°	60°	70°	80°	
Débit eau / Water flow rate / Wasser durchsatz / Caudal agua (l/mn) / 70 bar / 1.015 psi	Ø (pouce/") / Calibre / Size / Grösse	2XX / XX-07	3XX / XX-09	4XX / XX-11	5XX / XX-13	6XX / XX-15	7XX / XX-17	8XX / XX-19	Débit eau / Water flow rate / Wasser durchsatz / Caudal agua (l/mn) / 138 bar / 2.2002 psi
0.22 l/mn	0.009 / 04	209 / 04-07	309 / 04-09	409 / 04-11	509 / 04-13				0.33 l/mn
0.33 l/mn	0.011 / 06	211 / 06-07	311 / 06-09	411 / 06-11	511 / 06-13	611 / 06-15			0.49 l/mn
0.45 l/mn	0.013 / 09	213 / 09-07	313 / 09-09	413 / 09-11	513 / 09-13	613 / 09-15	713 / 09-17		0.69 l/mn
0.60 l/mn	0.015 / 12	215 / 12-07	315 / 12-09	415 / 12-11	515 / 12-13	615 / 12-15	715 / 12-17		0.91 l/mn
0.72 l/mn	0.017 / 14	217 / 14-07	317 / 14-09	417 / 14-11	517 / 14-13	617 / 14-15	717 / 14-17	817 / 14-19	1.17 l/mn
0.95 l/mn	0.019 / 18	219 / 18-07	319 / 18-09	419 / 18-11	519 / 18-13	619 / 18-15	719 / 18-17	819 / 18-19	1.47 l/mn
1.33 l/mn	0.021 / 25			421 / 25-11	521 / 25-13	621 / 25-15	721 / 25-17	821 / 25-19	1.79 l/mn
1.6 l/mn	0.023 / 30			423 / 30-11	523 / 30-13	623 / 30-15	723 / 30-17	823 / 30-19	2.15 l/mn
2.175 l/mn	0.025 / 40			425 / 40-11	525 / 40-13	625 / 40-15	725 / 40-17	825 / 40-19	2.54 l/mn
2.38 l/m	0.029 / 45		329 / 45-09	429 / 45-11	529 / 45-13	629 / 45-15	729 / 45-17	829 / 45-19	3.42 l/mn
3.78 l/mn	0.033 / 68			433 / 68-11	533 / 68-13	633 / 68-15	733 / 68-17	833 / 68-19	4.42 l/mn
5.11 l/mn	0.036 / 100				539 / 100-13	639 / 100-15	739 / 100-17	839 / 100-19	5.42 l/mn

Pour établir la référence d'une buse, remplacer les croix par le nombre repère de la buse précédé de 000.40X.XXX  
 Exemple : pour commander une buse 25.13, utiliser la référence : 000 402 513

To obtain tip part number, replace the crosses by the engraved tip number preceded by 000.40X.XXX  
 Example : use part number 000 402 513 to obtain tip 25.13

Die Bestell-Nr. für eine Wendedüse erhält man, indem man die Kreuze durch die vorgenannte Kennzahl ersetzt : 000.40X.XXX  
 Beispiel: für eine Düse 25.13 ergibt sich die Bestell-Nr. : 000 402 513

Para establecer la referencia de una boquilla reemplazar las cruces por el número de la boquilla precedido por 000.40X.XXX  
 ejemplo : para pedir una boquilla 25.13 emplear la referencia : 000 402 513

## BUSES PLATES - FLAT TIPS - STANDARD-DÜSEN - BOQUILLAS PLANAS

Les buses plates garantissent une grande précision dans leurs performances.  
Référence : 000.00X.XXX (remplacer les X par leur nombre gravé sur la buse).

Flat tips guaranty a very high precision in performance.  
Part number : 000.00X.XXX (replace X by the number engraved on the tip).

Die Flachstrahl-Düsen garantieren eine hohe Spritzstrahlpräzision.  
Bestell-Nr. : 000.00X.XXX (die X durch die auf der Düse gravierte Nummer ersetzen).

Las boquillas planas garantizan una gran precisión de resultados.  
Referencia : 000.00X.XXX (sustituir las X por las cifras gravadas en la boquilla).

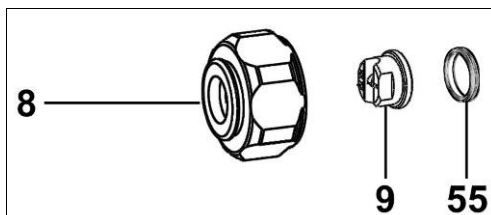

Ind	#	Désignation	Description	Bezeichnung	Denominación	Qté
8	129 740 071	Ecrou de serrage pour buse plate et buse Skill™ (voir accessoires)	Tightening nut for flat and Skill™ tip (refer to accessories)	Überwurfmutter für Standard- und Skill™-Düsen (siehe Zubehör)	Tuerca de presión para boquilla plana y boquilla Skill™ (consultar accesorios)	1
9	000 00x xxx	Buse plate Airless®	Flat airless tip	Airless Flachstrahl-Düse	Boquilla plana Airless	1
55	150 041 319	Joint pour buse plate (x 5)	Seal for flat tip (x 5)	Dichtung für Standard Airless-Düsen (5 St.)	Junta para boquilla plana (x 5)	1

## TABLEAU DES BUSES - TIP CHART - DÜSENTABELLE - CUADRO DE LAS BOQUILLAS

		Débit d'eau Water output Wasserdurchsatz Caudal agua (l / mn)	Diaphragme buse / Tip diaphragm / Vorzerstäuber / Restrictor boquilla	Largeur de jet à 25 cm / Spray fan width at 25 cm (10") Strahlbreite bei 25 cm Abstand / Ancho abanico à 25 cm												
				9	12	17	21	25	29	33	37	44	56			
Calibre Size Größe	Ø. mm	Pression / Pressure / Druck / Presión 140 bar / 2030 psi		Nombre gravé sur la buse / Number engraved on the tip Eingravierte Kennzahl auf der Düse / índice gravado sobre la boquilla												
03	0,18	0,23	12	03.03	03.05	03.07										
04	0,23	0,31	12	04.03	04.05	04.07	04.09	04.11	04.13							
06	0,28	0,46	12	06.03	06.05	06.07	06.09	06.11	06.13	06.15						
09	0,33	0,63	15	09.03	09.05	09.07	09.09	09.11	09.13	09.15	09.17					
12	0,38	0,86	15			12.07	12.09	12.11	12.13	12.15	12.17					
14	0,41	1,01	18	14.03	14.05	14.07	14.09	14.11	14.13	14.15	14.17	14.19				
18	0,46	1,34	18				18.09	18.11	18.13	18.15	18.17	18.19				
20	0,51	1,50	20		20.05	20.07	20.09	20.11	20.13	20.15	20.17	20.19				
25	0,56	1,88	20					25.11	25.13	25.15	25.17	25.19				
30	0,61	2,25	25			30.07	30.09	30.11	30.13	30.15	30.17	30.19				
40	0,66	3,25	25					40.11	40.13	40.15	40.17	40.19				
45	0,74	3,34	60			45.07		45.11	45.13	45.15	45.17	45.19	45.21			
68	0,91	5,60	60					68.11	68.13	68.15	68.17	68.19				

Le diaphragme augmente la finesse de pulvérisation - # : 000 029 1XX (remplacer les X par le nombre du diaphragme).

The diaphragm increases the quality finish - # : 000 029 1XX (replace X by the diaphragm number).

Der Vorzerstäuber verfeinert die Zerstäubung - # : 000 029 1XX (X durch die Nummer des Vorzerstäubers ersetzen).

El restrictor aumenta la calidad (finura) del pulverizado - # : 000 029 1XX (sustituir las X por las cifras gravadas en el restrictor).

## BUSES SKILL™ - SKILL™ TIPS - DÜSEN SKILL™ - BOQUILLAS SKILL™

# : 000 30X XXX    remplacer les X par leur nombre gravé sur la buse / replace X by the number engraved on the tip  
 / die X durch die auf der Düse eingravierte Nummer ersetzen / sustituir las X por las cifras gravadas en la boquilla

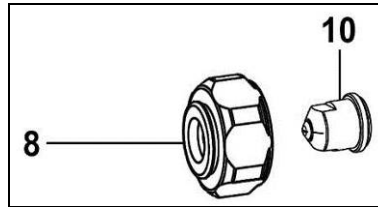

### TABLEAU DES BUSES - TIP CHART - DÜSENTABELLE - CUADRO DE LAS BOQUILLAS

		Débit d'eau Water output Wasserdurchsatz Caudal agua (l / mn)	Largeur de jet à 25 cm / Spray fan width at 25 cm (10") Strahlbreite bei 25 cm Abstand / Ancho abanico à 25 cm							
			9	12	17	21	25	29	33	37
Calibre Size Größe	Ø. mm	Pression / Pressure / Druck / Presión 138 bar / 2000 psi	Nombre gravé sur la buse / Number engraved on the tip Eingravierte Kennzahl auf der Düse / índice gravado sobre la boquilla							
04	0,23	0,33		04.07	04.09	04.11	04.13			
06	0,28	0,49		06.07	06.09	06.11	06.13	06.15		
07	0,30	0,60	07.05	07.07	07.09	07.11	07.13	07.15		
09	0,33	0,69		09.07	09.09	09.11	09.13	09.15	09.17	
12	0,38	0,91					12.13	12.15	12.17	
14	0,41	1,17					14.13	14.15	14.17	14.19
18	0,46	1,47					18.13	18.15	18.17	18.19
20	0,50	1,56					20.13	20.15	20.17	20.19

Ind	#	Désignation	Description	Bezeichnung	Denominación	Qté
8	129 740 071	Ecrou de serrage pour buse plate et buse Skill™ (voir accessoires)	Tightening nut for flat and Skill™ tip (refer to accessories)	Überwurfmutter für Standard- und Skill™-Düsen (siehe Zubehör)	Tuerca de presión para boquilla plana y boquilla Skill™ (consultar accesorios)	1
10	000 30x xxx	Buse Skill™	Skill™ tip	Skill™ Düse	Boquilla Skill™	1
-	134 980 002	Pochette de collerette (x10)	Package of bearing (x 10)	Abschlussdeckel (Satz à 10 Stück)	Bolsa de anillo de cierre (x 10)	1

\* Pièces de maintenance préconisées.

\* Preceding the index number denotes a suggested spare part.

\* Bezeichnete Teile sind empfohlene Ersatzteile.

\* Piezas de mantenimiento preventivas.

N C : Non commercialisé.

N S : Denotes parts are not serviceable.

N S : Bezeichnete Teile gibt es nicht einzeln, sondern nur komplett .

N S : no suministrado.



# AIRLESS AUTOMATIC GUN

# PREVENTIVE MAINTENANCE

## TRANSLATION FROM THE ORIGINAL MANUAL

***IMPORTANT : Before assembly and start-up, please read and clearly understand all the documents relating to this equipment (professional use only).***

THE PICTURES AND DRAWINGS ARE NON CONTRACTUAL. WE RESERVE THE RIGHT TO MAKE CHANGES WITHOUT PRIOR NOTICE.

**SAMES KREMLIN SAS**  
13, chemin de Malacher  
38 240 - MEYLAN - France  
☎ : 33 (0)4 76 41 60 60

**[www.sames-kremlin.com](http://www.sames-kremlin.com)**



#### Safety instructions :

- Never point the spray gun at anyone or at any part of the body. Never try to stop the spray fan with any part of the body (hands, fingers...) or with rags.
- The operator will need medical attention if the high pressure material spray is in contact with the the body (eyes, fingers...).
- **Always depressurize air and hoses** before carrying out any servicing on the gun.



In order to protect the operator, protective clothing (gloves, respirator mask, glasses, hearing protective earplug, clothes...) are required.

Use the equipment in a properly ventilated area.

This spray gun is a precision tool. Its correct functioning requires regular maintenance, carried out with care. When it is carried out directly after use, the cleaning of the gun is faster and easier.

➔ **Never use metallic brushes, files or pliers when dismantling the gun.**

#### ▪ **SHORT DURATION SHUTDOWN (LESS THAN 3 HOURS)**

Leave the equipment as it is. In any case, if the tip becomes a little clogged with material, it is best to clean it with a brush and some solvent.

#### ▪ **LONG DURATION SHUTDOWN**

Shut off gun air and fluid supply.

Change material with solvent and trigger the gun to depressurize the product circuits and flush the pump, the hoses and the gun.

Unscrew the aircap ring to remove the reversing tip, the flat tip or the Skill™ tip. Put it in the solvent to soak and then brush it clean. Remove the seat holder. Remove the needle gun frontwards. Soak the tip. Brush it. Clean inside the gun with a brush and solvent. Insist particularly on threads.

Flush the gun.

➔ **Never soak the gun itself in solvent.**

➔ **Use only products or solvent compatible with the parts in contact with the material (refer to data sheet of the material manufacturer).**



# AIRLESS AUTOMATIC GUN

## TROUBLESHOOTING GUIDE

### TRANSLATION FROM THE ORIGINAL MANUAL

***IMPORTANT : Before assembly and start-up, please read and clearly understand all the documents relating to this equipment (professional use only).***

THE PICTURES AND DRAWINGS ARE NON CONTRACTUAL. WE RESERVE THE RIGHT TO MAKE CHANGES WITHOUT PRIOR NOTICE.

**SAMES KREMLIN SAS**  
13, chemin de Malacher  
38 240 - MEYLAN - France  
☎ : 33 (0)4 76 41 60 60

**[www.sames-kremlin.com](http://www.sames-kremlin.com)**

TROUBLE	CAUSE	SOLUTION
Material is no longer coming out of the gun	Clogged tip	Check gun material supply. Shut off pressure on pump. Depressurize the hoses. Remove and clean spray tip and filter.
Spray fan is not uniform	Tip partially clogged	For the reversible tip, pivot the tip at 180 degree to unclog it. If no improvement : remove it and change it. For the flat tip, remove it and change it.
	Unappropriate tip	Use an appropriate tip size
	Worn tip	Change tip
	Fluid cannot be sprayed	Increase pump supply air pressure
	Material viscosity too high	Reduce viscosity
Pattern width narrows during reversing phase of pump	Air trapped in the fluid circuit	Check connection and suction hose quality
	Viscosity too high	Reduce viscosity
Air cap becomes dirty frequently	Too much air	Reduce air pressure
	Seat-holder leaking	Replace the seat-holder
Fluid leak	Bad tightness between the needle ball and its seat	Clean the seat or replace the needle and the seat
	Worn cartridge	Replace the cartridge
	Seat holder loose or defective	Tighten the seat holder or change it
	Defective reversible tip seal	Change it
	Defective seat	Change it
	Head ring not correctly tightened	Tighten it
	Inlet fitting loose or defective on base	Tighten the fitting on the base or change it
Material inlet PTFE seals defective	Change the seals	



# AUTOMATIC SPRAYING GUN

## OPERATING PRINCIPLE

### TRANSLATION FROM THE ORIGINAL MANUAL

*IMPORTANT : Before assembly and start-up, please read and clearly understand all the documents relating to the equipment (professional use only).*

THE PICTURES AND DRAWINGS ARE NOT CONTRACTUAL. WE RESERVE THE RIGHT TO MAKE CHANGES WITHOUT PRIOR NOTICE.

**SAMES KREMLIN SAS**  
13, chemin de Malacher  
38 240 - MEYLAN - France  
☎ : 33 (0)4 76 41 60 60

**[www.sames-kremlin.com](http://www.sames-kremlin.com)**



# 1. OPERATING



**Safety instructions :**

- Never try to stop the spray fan with any part of the body (hands, fingers...) or with rags. Never point the spray gun at anyone or at any part of the body.
- The operator will need medical attention if the high pressure material spray is in contact with the the body (eyes, fingers...).
- **Always lock the gun trigger with the safety device when not operating the gun.**
- **Always depressurize air and hoses** before carrying out any servicing on the gun.



In order to protect the operator, protective clothing (gloves, respirator mask, glasses, hearing protective earplug, clothes...) are required

Use the equipment in a properly ventilated area.

Unscrew the tip coupling nut at the front of the gun.

Select the desired tip best suited for the job at hand. Select a tip that will meet both the desired material output and fan pattern requirements.

Before finally tightening up the coupling nut, position the tip for the required spray position (vertical or horizontal fan).

Spray onto a sheet of paper and progressively increase pump air pressure to assure full and even fan pattern.

# 2. USING ADVICE

Keep the gun perpendicular to the surface to be painted.

Do not forget that crossed sweeps cannot correct irregularities.

Spraying from a stationary gun will not give even coverage.

Make sure that overlapping from the passes is even (gun moving vertically, part moving horizontally).

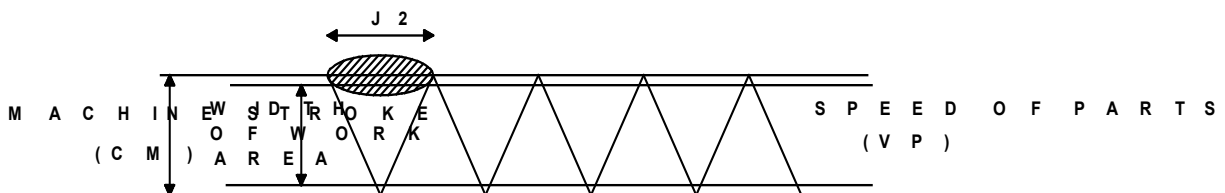

This width J2 for two regular coats of paint corresponds exactly to the following formula :

$$J 2 (m) = VP (m/s) \times 2 \frac{CM (m)}{VM (m/s)}$$

Where :

**VP** = speed of travel of the parts to be painted.

**CM** = total stroke of the machine (and therefore of the spray guns).

**VM** = speed of the machine (and therefore of the spray guns).

**2** = 2 regular coats of paint (or 4 if you want to double the number of coats).

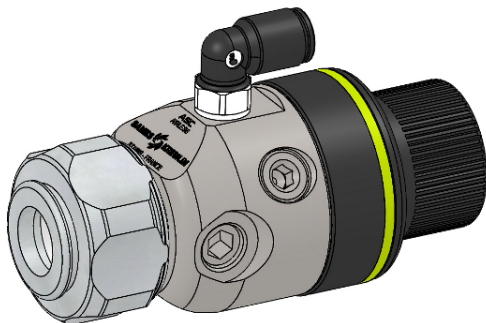

## AUTOMATIC AIRLESS GUN

***ASC 240 and 400***

***TECHNICAL FEATURES***

### TRANSLATION FROM THE ORIGINAL MANUAL

***IMPORTANT : Before assembly and start-up, please read and clearly understand all the documents relating to this equipment (professional use only).***

THE PICTURES AND DRAWINGS ARE NON CONTRACTUAL. WE RESERVE THE RIGHT TO MAKE CHANGES WITHOUT PRIOR NOTICE.

**SAMES KREMLIN SAS**  
13, chemin de Malacher  
38 240 - MEYLAN - France  
☎ : 33 (0)4 76 41 60 60

**[www.sames-kremlin.com](http://www.sames-kremlin.com)**

## 1. DESCRIPTION

The automatic AIRLESS ASC gun is designed for applying paints, primers, adhesives in automatic installations. It can be fitted on fixed supports, automatic machines or robots.

## 2. TECHNICAL FEATURES

FEATURES	GUN, MODEL 240 bar	GUN, MODEL 400 bar
Maximum air supply pressure	6 bar/14.5 psi max.	
Maximum fluid supply pressure	<b>240 bar / 3481 psi</b>	<b>400 bar / 5802 psi</b>
Flow rate	Dependent upon nozzle (refer to chart)	
Weight (gun only, without manifold)	397g / 0.88lb	
Operating maximum temperature	40°C / 104°F	
Wetted parts	Stainless	
Seat (removal)	Carbide	
Weighted sound pressure (LAeq) (at 1m - depending upon ISO 3746 standard)	78,4dBa	

### ▪ AIR AND FLUID FITTINGS WITH HOSES

Supply	Threadings	Fittings
Fluid (P1)	M 1/2 JIC	M 1/2 JIC
Command air (AC)	F G 1/8	4x6 Quick fit



Applicate glue on the threading of the fluid fittings before assembling (similar to Loctite 577).

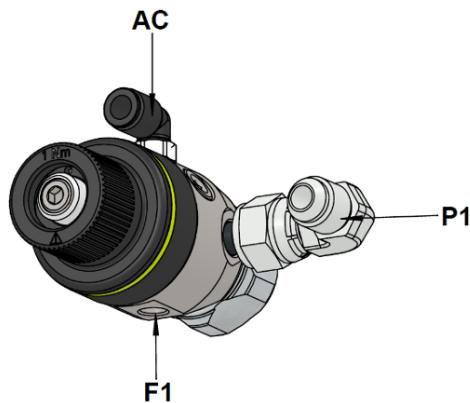

Fixing of the gun in F1 : rod Ø6.75 M8



The grounding of the gun will be carried out by means of the bracket (also grounded) or by means of a conductive material hose.

▪ DIMENSIONS : ASC GUN

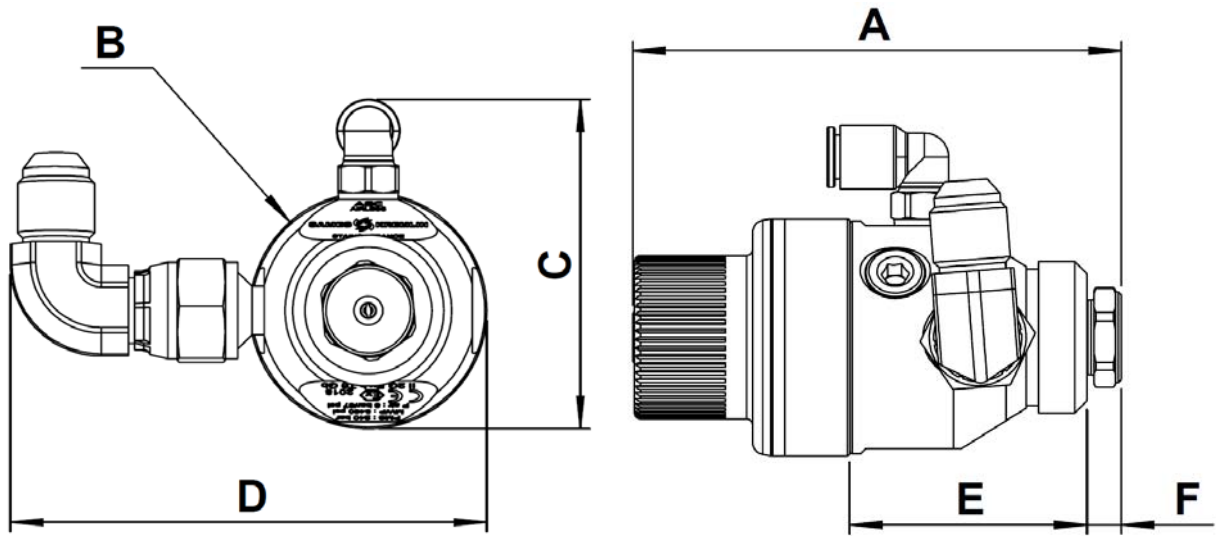

Ind.	A	B	C	D	E	F
mm	80.6	Ø39.2	54.5	78.7	39.1	5.7
"	3.1	Ø1.5	2.1	3.1	1.5	0.2

Bottom view

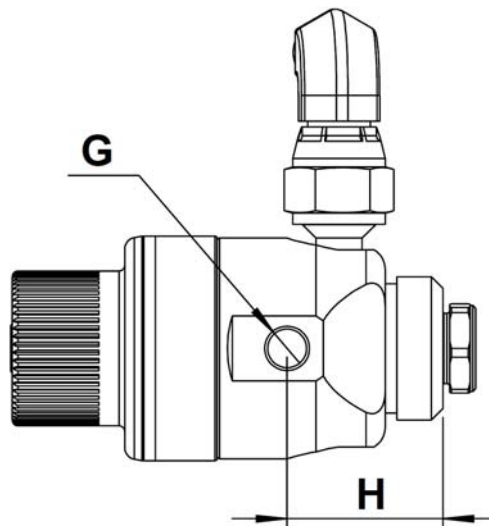

Ind.	G	H
mm	Ø6.8	27
"	Ø2.4	10.6

### 3. INSTALLATION

▪ DESCRIPTION OF THE LABEL MARKING



Marking in accordance with the ATEX regulation

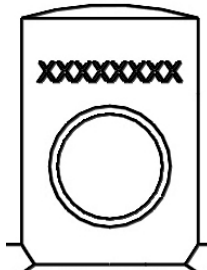

*model 240 bar / 3481 psi*



*model 400 bar / 5802 psi*

<b>SAMES KREMLIN STAINS FRANCE</b>	Name and address of the manufacturer
<b>ASB</b>	Gun model
<b>CE</b>  <b>II 2 G</b>	<b>CE</b> : European conformity  : For use in explosive area <b>II</b> : group II <b>2</b> : class 2 <b>G</b> : gas Surface equipment meant to an area where explosive atmospheres due to gas, vapours, mists are liable to appear from time to time in usual operating.
<b>Ex h IIB T6</b>	<b>Ex</b> : Marking of conformity with European standards <b>h</b> : Mode of protection for non electrical device <b>IIB</b> : Gas group <b>T6</b> : Temperature class - Maximum surface temperature : 85°C / 185° F
<b>Gb</b>	<b>Gb</b> : Equipment protection level (Gas zone1)
<b>20xx</b>	Marking of the manufacturing year (with 4 characters)
<b>P air : 6 bar / 87 psi</b>	Gun air supply maximum pressure
<b>PMS : 240 bar MWP : 3480 psi</b>	Maximum fluid pressure at the gun inlet (240 bar model)
<b>PMS : 400 bar MWP : 5800 psi</b>	Maximum fluid pressure at the gun inlet (400 bar model)
<b>xxxxxxx</b>	Serial number

■ INSTALLATION DIAGRAM

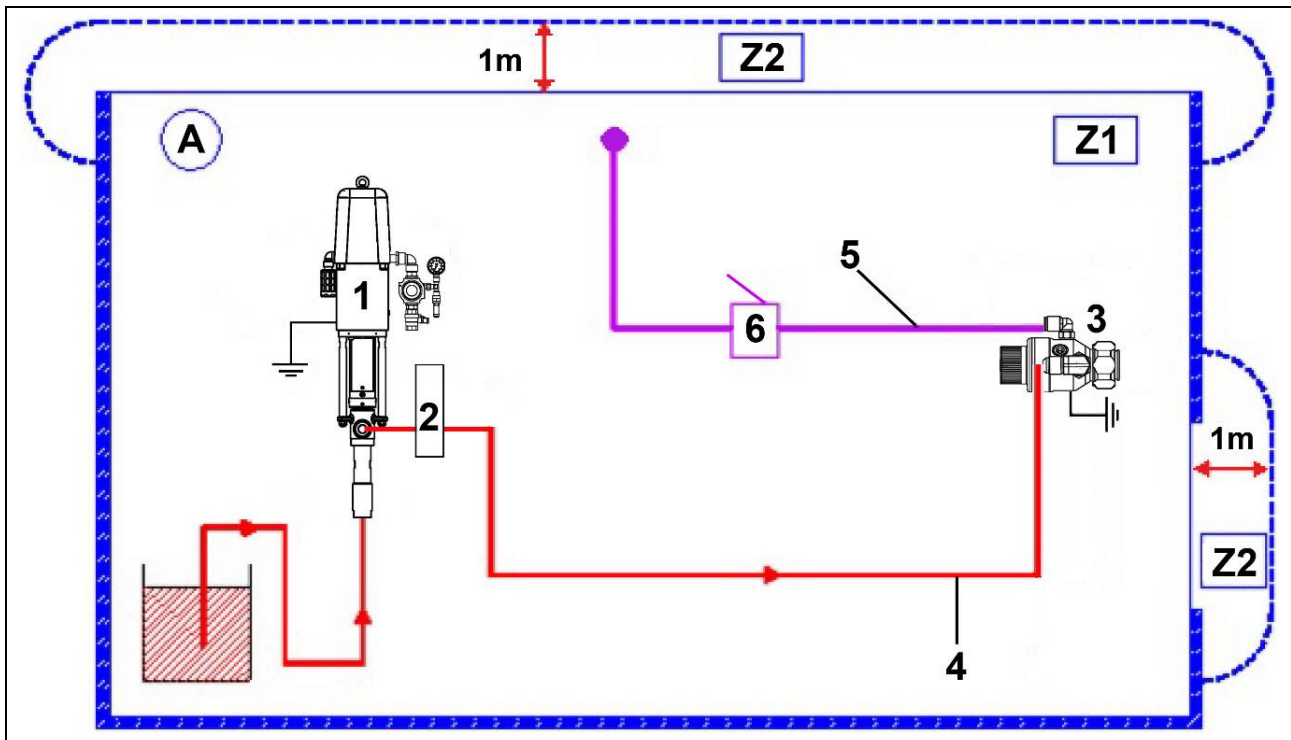

Captions :

A	Explosive area area 1 (Z1) or area 2 (Z2) : spray booth
---	---

1	Pump
2	Filter
3	Airless automatic gun
4	<b>Conductive</b> HP fluid hose
5	Air hose (control air)
6	3 way-valve or electrovalve

- 1 - By means of a conductive high pressure fluid hose (3), connect the gun fluid fitting to the pump. Tighten firmly the fittings.
- 2 - By means of an air hose (4), connect the gun 'Control air' fitting to the valve or the electrovalve (5) that will control the opening and the closing of the gun.

**A minimum pressure of 3 or 4 bar / 43.5 or 8 psi is necessary to control the gun (→ control air).**



Nota : The gun **must be** grounded by, **at least**, one of the three next solutions :

- by means of the fixing device on the machine,
- by means of the static conductive air hose,
- by means of the conductive or static conductive fluid hose.

The ground resistance between the gun and the floor must be  $\leq 1 \text{ M}\Omega$ .



The 1m / 39.37" distance indicated in these diagrams is given for information purposes only and hold harmless to SAMES KREMLIN. The user is responsible for the extraction and conditioning of the painting area where the equipment is used, for working conditions conditions (refer to EN 60079-10 standard).

The 1m / 39.37" distance may be modified if trials carried out by the user deem this necessary.